



ISClass

**GUIDELINES FOR IMPLEMENTATION OF
SOLAS 2009 REQUIREMENTS FOR
SUBDIVISION AND DAMAGE STABILITY**

2009

Effective from January 1 2009

CONTENTS

Part A	GENERAL.....	1
Regulation 1	Application.....	1
Regulation 2	Definitions.....	1
Part B	SUBDIVISION AND STABILITY.....	4
Regulation 4	General requirements.....	4
Part B-1	STABILITY.....	4
Regulation 5	Intact stability.....	4
Regulation 5-1	Stability information to be supplied to the master.....	5
Regulation 6	Required subdivision index R	6
Regulation 7	Attained subdivision index A	6
Regulation 7-1	Calculation of the factor p_i	9
Regulation 7-2	Calculation of the factor s_i	18
Regulation 7-3	Permeability.....	23
Regulation 8	Special requirements concerning passenger ship stability.....	24
Regulation 8-1	System capabilities after a flooding casualty on passenger ships.....	24
Part B-2	SUBDIVISION, WATERTIGHT AND WEATHERTIGHT INTEGRITY	24
Regulation 9	Double bottoms in passenger ships and cargo ships other than tankers.....	24
Regulation 10	Construction of watertight bulkheads.....	26
Regulation 12	Peak and machinery space bulkheads, shaft tunnels, etc.....	26
Regulation 13	Openings in watertight bulkheads below the bulkhead deck in passenger ships.....	27
Regulation 13-1	Openings in watertight bulkheads and internal decks in cargo ships.....	31
Regulation 14	Passenger ships carrying goods vehicles and accompanying personnel.....	32
Regulation 15	Openings in the shell plating below the bulkhead deck of passenger ships and the freeboard deck of cargo ships.....	32
Regulation 15-1	External openings in cargo ships.....	32
Regulation 16	Construction and initial tests of watertight doors, sidescuttles, etc.....	33
Regulation 17	Internal watertight integrity of passenger ships above the bulkhead deck.....	33
Regulation 17-1	Integrity of the hull and superstructure, damage prevention and control on ro-ro passenger ships.....	34
Part B-4	STABILITY MANAGEMENT.....	34
Regulation 19	Damage control information.....	34
Regulation 22	Prevention and control of water ingress, etc.....	36
Regulation 22-1	Flooding detection systems for passenger ships carrying 36 or more persons constructed on or after 1 July 2010.....	37
Appendix 1	Guidelines for the Preparation of Subdivision and Damage Stability Calculations.....	38
Appendix 2	Cross-reference Tables of Regulations of SOLAS Chapter II-1.....	41
Appendix 3	List of Relevant Instruments.....	68

Part A GENERAL

Regulation 1 Application

Regulation 1.3

1 If a passenger ship built before 1 January 2009 undergoes alterations or modifications of major character, it may still remain under the damage stability regulations applicable to ships built before 1 January 2009, except in the case of a cargo ship being converted to a passenger ship.

2 Conversions of single-hull tankers to double-hull tankers are regarded as modifications of a major character for the purposes of SOLAS chapter II-1.

3 Repairs, alterations and modifications of a major character include:

(1) Substantial alteration of the dimensions of a ship, for example: Lengthening of a ship by adding a new midbody. The new midbody is to comply with SOLAS chapter II-1.

(2) A change of ship type, for example: A tanker converted to a bulk carrier. Any structure, machinery and systems that are added or modified are to comply with SOLAS chapter II-1 taking into account the interpretation Reg. 3-2.2 and Reg. 3-2.4.

4 In the context of conversions of single-hull tankers to double-hull tankers, the retrofitting requirements are to be decided on a case-by-case basis (refer to IACS UI SC226).

Regulation 2 Definitions

Regulation 2.1

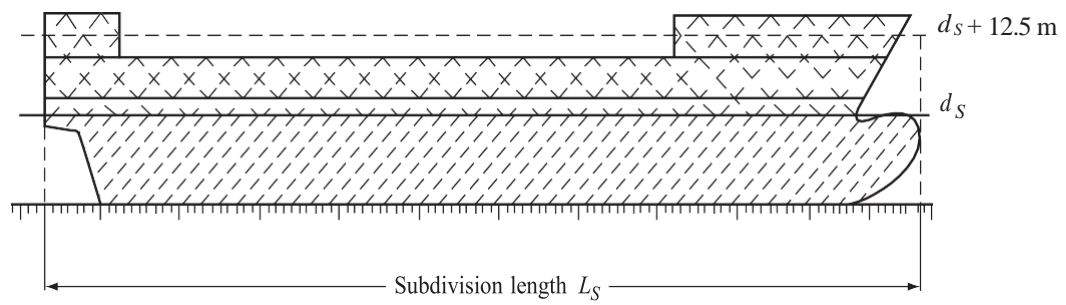
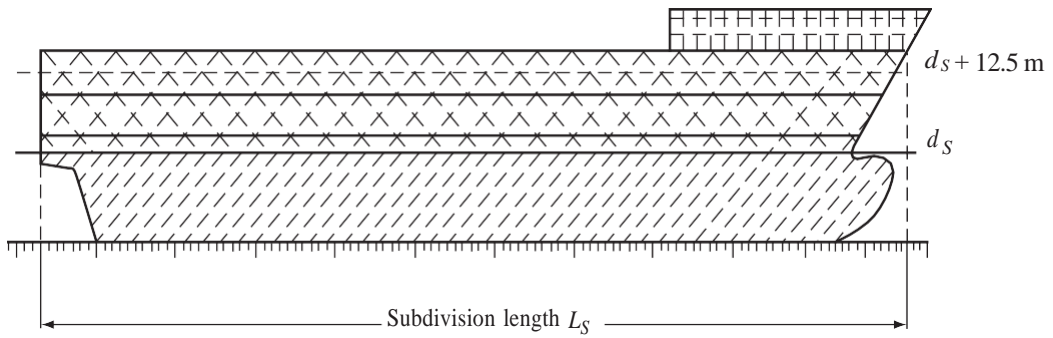
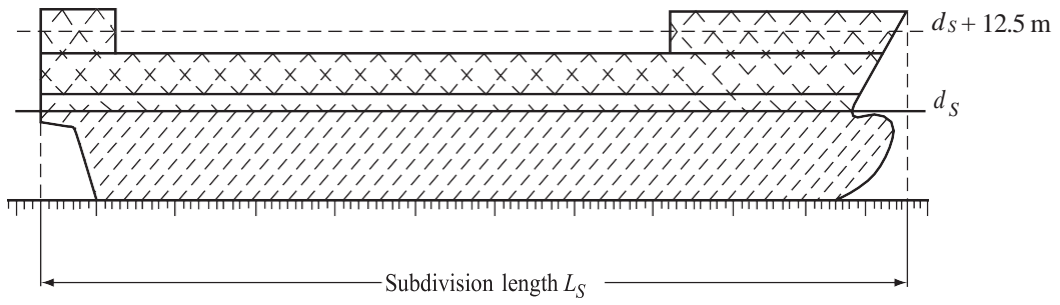

1 Subdivision length (L_s)—Different examples of L_s showing the buoyant hull and the reserve buoyancy are provided in the figures below. The limiting deck for the reserve buoyancy may be partially watertight. The watertight part upwards the deck may be added into the reserve buoyancy. And L_s is to be measured by using moulded dimensions.

2 The maximum possible vertical extent of damage above the baseline is $d_s + 12.5$ m.

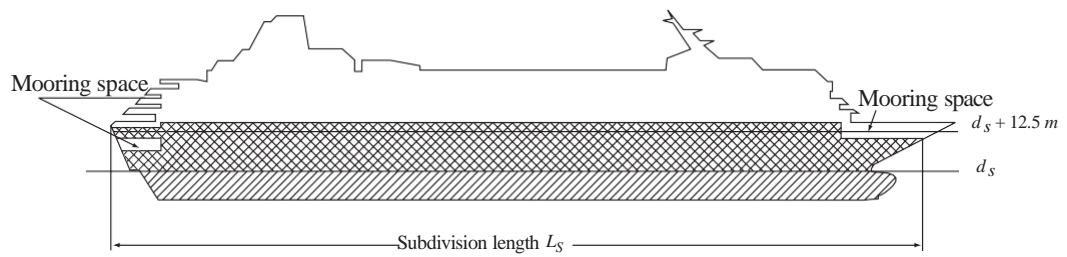

 Buoyant hull
  Reserve buoyancy
  Reserve buoyancy, not subject to damage



 Buoyant hull
 Reserve buoyancy

Regulation 2.6

Freeboard deck—See regulation 13-1 for the treatment of a stepped freeboard deck with regard to watertightness and construction requirements.

Regulation 2.7

Forward perpendicular is the forward perpendicular as defined in the International Convention on Load Lines in force, namely the perpendiculars taken at the forward end of the length (L) as defined in LL Convention. See Guidance for Regulation 12 for the position of the forward perpendicular.

Regulation 2.11

Light service draught (d_l)—The light service draught (d_l) represents the lower draught limit of the minimum required GM (or maximum allowable KG) curve. It corresponds, in general, to the ballast arrival condition with 10% consumables for cargo ships. For passenger ships, it corresponds, in general, to the arrival condition with 10% consumables, a full complement of passengers and crew and their effects, and ballast as necessary for stability and trim. The 10% arrival condition is not necessarily the specific condition that is to be used for all ships, but represents, in general, a suitable lower limit for all loading conditions. This is understood to not include docking conditions or other non-voyage conditions.

Regulation 2.13

1 Trim is the difference between the draught forward and the draught aft of the subdivision length (L_s). The aft and forward terminals are defined by regulations 2.3 and 2.4 respectively as the aft and forward limits of the subdivision length. The trim is used for calculating the limiting GM curves in regulations 5-1 (Stability information to be supplied to the master) and 7 (Attained subdivision index A).

2 Particular attention is to be paid to the difference between the trim defined above and the one in hydrostatic calculation. In hydrostatic calculation: the trim is taken as the difference between the draught forward and the draught aft of L_{BP} . The L_{BP} is the horizontal distance between forward (F.P) and aft perpendiculars (A.P). The forward perpendicular is the perpendicular at the intersection of the design waterline with the fore side of the stem. The after perpendicular is generally at the after side of the rudder post, and for ships without a rudder post, with the centreline of the rudder stock.

Regulation 2.14

Permeability—In determining the damage stability, the volume of a space is to be taken as the moulded volume, i.e. the immersed volume of a space shall be the under water moulded volume of that space multiplied by the permeability.

Regulation 2.19

Bulkhead deck—See regulation 13 of the Guidelines for the treatment of a stepped bulkhead deck with regard to watertightness and construction requirements.

Part B SUBDIVISION AND STABILITY

Regulation 4 General requirements

Regulation 4.1

Cargo ships complying with the subdivision and damage stability regulations of other IMO instruments listed in the footnote are not required to comply with part B-1, regulations 6, 7, 7-1, 7-2 and 7-3, but are to comply with the regulations of SOLAS 2009 indicated below:

- (1) Part B-1: Regulations 5, 5-1;
- (2) Part B-2: Regulations 9^①, 10, 11, 12, 13-1, 15, 15-1, 16, 16-1;
- (3) Part B-4: Regulations 19, 22, 24, 25^②.

Regulation 4.1, footnote .1

“OBO ships” means combination carriers as defined in SOLAS regulation II-2/3.14.

Regulation 4.4

See for regulation 7-2.2 of the Guidelines.

Part B-1 STABILITY

Regulation 5 Intact stability

1 A sister ship is a ship built by the same yard from the same plans.

1.1 The acceptable deviation of lightship displacement is to be:

for $L \leq 50$ m	2% of the lightship displacement of the lead ship;
for $L \geq 160$ m	1% of the lightship displacement of the lead ship;
for intermediate length	by linear interpolation.

1.2 Deviation of lightship longitudinal centre of gravity

The deviation of lightship longitudinal centre of gravity is not to exceed 0.5% L_s of the lead ship and the sister ships.

Where the deviation is within these limits, an inclining test may be exempted.

“ L ”— the length defined in the International Convention on Load Lines.

① Only applies to cargo ships other than tankers.

② Only applies to single hold cargo ships other than bulk carriers.

2 Requirements for all conditions are as follows.

2.1 For any newly built sister ship with known differences from the lead sister ship, a detailed weights and centres calculation to adjust the lead ship's lightship properties is to be carried out. The validity of the calculated lightship properties is to be assessed by carrying out a lightweight check unless the implications regarding the stability of the ship indicate that an inclining test is to be performed. Where the deviation is within these limits the actual lightship weight and longitudinal centre of gravity derived from the lightship check are to be used in conjunction with the higher of either the lead ship's vertical centre of gravity or the calculated value.

2.2 For a ship in service which undergoes alterations with calculable differences in lightship properties which materially affect the stability information supplied to the master, a detailed weights and centres calculation to adjust the lightship properties is to be carried out. To avoid an inclining test, the deviation of lightship displacement is not to exceed 2% of the original approved lightweight or 2 tonnes, whichever is greater, or that approved following the most recent major alteration or conversion. In addition, the deviation of lightship longitudinal centre of gravity from the original or that approved following the most recent major alteration or conversion is not to exceed 1% L_s of the ship. Where a ship is within these limits the calculated values of lightweight, lightship LCG and lightship VCG are to be used in all subsequent stability information supplied to the master.

2.3 For all passenger ships, a lightship survey is to be carried out at periodical intervals not exceeding five years to verify any changes in lightship displacement and longitudinal centre of gravity. The ship is to be re-inclined whenever, in comparison with the originally approved stability information or that approved following the most recent major alteration or conversion, the deviation of the lightweight and/or lightship longitudinal centre of gravity exceeds the limits in 2.2 above. Where a ship is within these limits, the values of lightweight and lightship LCG derived from the lightship survey are to be used in conjunction with the VCG derived from the most recent inclining experiment in all subsequent stability information supplied to the master.

Regulation 5-1 Stability information to be supplied to the master

Regulation 5-1.2

The requirements in regulation 6.1, regulation 8 or regulation 9, which are in addition to those described in regulation 5-1.4, are to be taken into account when developing this information.

Regulations 5-1.3 and 5-1.4 (see also regulation 7.2)

1 Linear interpolation of the limiting values between the draughts d_s , d_p and d_l is only applicable to minimum GM values. If it is intended to develop curves of maximum permissible KG , a sufficient number of KM_T values for intermediate draughts are to be calculated to ensure that the resulting maximum KG curves correspond with a linear variation of GM . When light service draught is not with the same trim as other draughts, KM_T for draughts between partial and light service draught is to be calculated for trims interpolated between trim at partial draught and trim at light service draught.

2 In cases where the operational trim range is intended to exceed $\pm 0.5\%$ of L_s , the original GM limit line is to be designed in the usual manner with the deepest subdivision draught and partial subdivision draught calculated at level trim and actual service trim used for the light service draught. Then additional sets of GM limit lines are to be constructed on the basis of the operational range of trims which is covered by loading conditions of partial subdivision draught and deepest subdivision draught^① ensuring that intervals of 1% L_s are not exceeded. For the light service draught d_l only one trim is to be considered. The sets of GM limit lines are combined to give one envelope limiting GM curve. The effective trim range of the curve is to be clearly stated.

^① Loading conditions of partial subdivision draught and deepest subdivision draught mean the cargo loading condition.

3 For ships with timber deck cargoes the limiting *GM* curves applicable for loading conditions for timber deck cargo are to be developed in addition to the limiting *GM* curves for loading conditions for general cargo. Deepest timber subdivision draught is the waterline which corresponds to the timber summer draught to be assigned to the ship; partial timber subdivision draught is the light service draught as defined in SOLAS Reg.II-1/2.11 plus 60% of the difference between the light service draught and the deepest timber subdivision draught. The permeability of the timber deck cargo is not to be less than 25% of the volume occupied by the cargo up to one standard superstructure. See regulation 7-3.2 for the permeability of timber deck cargo.

Regulation 6 Required subdivision index *R*

Regulation 6.1

To demonstrate compliance with these requirements, see Appendix 1 of the Guidelines — Guidelines for the preparation of subdivision and damage stability calculations.

Regulation 6.2.4

Regarding the term “reduced degree of hazard”, the following interpretation is to be applied: A lesser value of *N*, but in no case less than $N = N_1 + N_2$, may be allowed at the discretion of the Administration for passenger ships, which, in the course of their voyages, do not proceed more than 20 miles from the nearest land.

Regulation 7 Attained subdivision index *A*

Regulation 7.1

1 The probability of surviving after collision damage to the ship’s hull is expressed by the index *A*. Producing an index *A* requires calculation of various damage scenarios defined by the extent of damage and the initial loading conditions of the ship before damage. Three loading conditions are to be considered and the result weighted as follows:

$$A = 0.4A_s + 0.4A_p + 0.2A_l$$

where the indices *s*, *p* and *l* represent the three loading conditions d_s , d_p , d_l and the factor to be multiplied to the index indicates how the index *A* from each loading condition is weighted.

2 The method of calculating *A* for a loading condition is expressed by the formula:

$$A_c = \sum_{i=1}^{i=t} p_i [v_i s_i]$$

2.1 The index *c* represents one of the three loading conditions, the index *i* represents each investigated damage or group of damages and *t* is the number of damages to be investigated to calculate A_c for the particular loading condition.

2.2 To obtain a maximum index *A* for a given subdivision, *t* has to be equal to *T*, the total number of damages.

3 In practice, the damage combinations to be considered are limited either by significantly reduced contributions to A (i.e. flooding of substantially larger volumes) or by exceeding the maximum possible damage length.

4 The index A is divided into partial factors as follows:

- p_i The p factor is solely dependent on the geometry of the watertight arrangement of the ship.
- v_i The v factor is dependent on the geometry of the watertight arrangement (decks) of the ship and the draught of the initial loading condition. It represents the probability that the spaces above the horizontal subdivision will not be flooded.
- s_i The s factor is dependent on the calculated survivability of the ship after the considered damage for a specific initial condition.

5 Three initial loading conditions are to be used for calculating the index A . The loading conditions are defined by their mean draught d , trim and GM (or KG). The mean draught and trim are illustrated in the figure below.

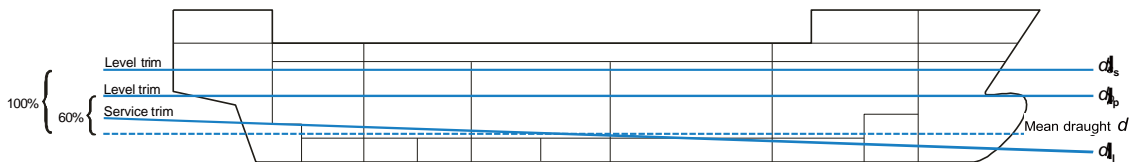

6 The GM (or KG) values for the three loading conditions could, as a first attempt, be taken from the intact stability GM (or KG) limit curve. If the required index R is not obtained, the GM (or KG) values may be increased (or reduced), implying that the intact loading conditions from the intact stability book must now meet the GM (or KG) limit curve from the damage stability calculations derived by linear interpolation between the three GM s.

Regulation 7.2

1 The calculations for differing trim are to be carried out with the same initial trim for the partial and deepest subdivision draughts. For the light service draught, the actual service trim is to be used (see for regulation 2.11 of the Guidelines).

2 Each combination of the index within the formula given in regulation 7.1 is not to be less than the requirement given in regulation 6.2. Each partial index A (A_p , A_s) is to comply with the requirements of regulation 6.1. Based on the GM limiting curves obtained from damage stability calculations of each trim, an envelope curve covering all calculated trim values is to be developed.

3 Example:

3.1 In calculating the GM curves, the trim is to be taken as zero if it is within $\pm 0.5\% L_s$. Calculations covering different trim values are to be carried out in steps not exceeding 1% of L_s while the trim is over $\pm 0.5\% L_s$. For example, trim ranges from $0.5\% L_s$ forward to $-1.5\% L_s$ aft in all loading conditions, the following two limiting GM curves are to be calculated: partial subdivision draught and deepest subdivision draught are to be calculated as “trim = 0” and “trim = $-1.0\% L_s$ ” respectively, the light service draught is to be taken as the actual trim. “trim = 0” means the range of trim from $-0.5\% L_s$ to $+0.5\% L_s$; “trim = $-1.0\% L_s$ ” means the range of trim from $-0.5\% L_s$ to $-1.5\% L_s$. Based on the GM limiting curves obtained from damage stability calculations of each trim, an envelope curve covering all calculated trim values as shown in the figure below is developed.

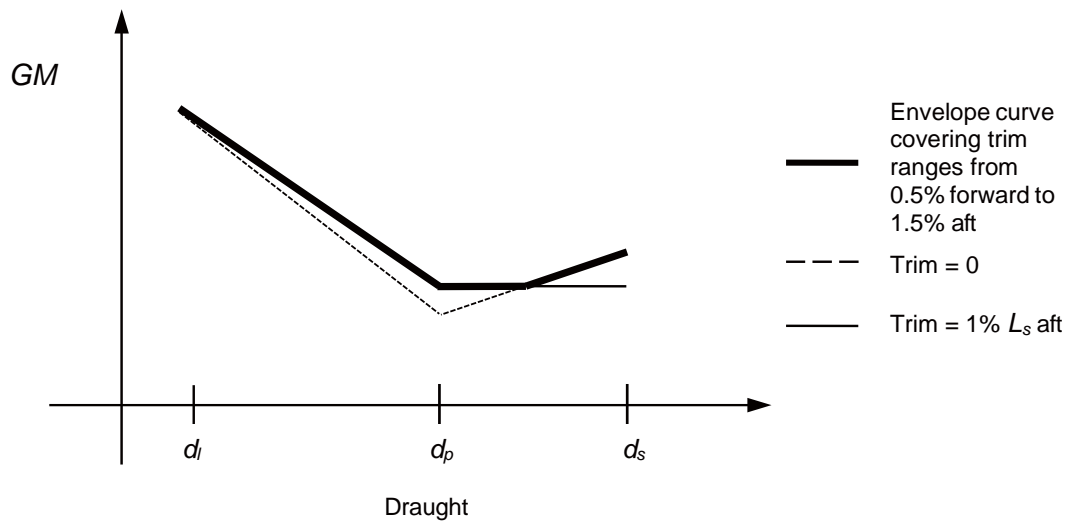

3.2 Stability information to be supplied to the master is to include GM limiting curves of damage stability and is to include the description: “The GM as corrected by free surface in any loading condition is to meet the requirements for GM limiting curves of damage stability in addition to those for GM limiting curves of intact stability.”

3.3 For ships with timber deck cargoes the limiting GM curves applicable for loading conditions for timber deck cargo are to be developed in addition to the limiting GM curves for loading conditions for general cargo (see for regulation 5-1.4 of the Guidelines).

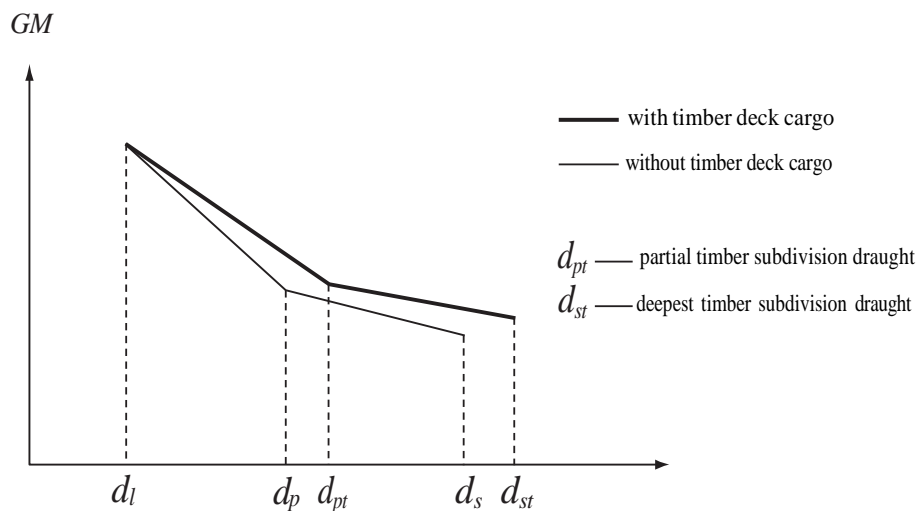

Regulation 7.5

1 With the same intent as wing tanks, the summation of the attained index A is to reflect effects caused by all watertight bulkheads and flooding boundaries within the damaged zone. It is not correct to assume damage only to the centreline and ignore changes in subdivision that would reflect lesser contributions.

2 In the forward and aft ends of the ship where the sectional breadth is less than the ship's breadth B , transverse damage penetration can extend beyond the centreline bulkhead. This application of the transverse extent of damage is consistent with the methodology to account for the localized statistics which are normalized on the greatest moulded breadth B rather than the local breadth.

3 Where longitudinal corrugated bulkheads are fitted in wing compartments or on the centreline, they may be treated as equivalent plane bulkheads provided the corrugation depth is of the same order as the stiffening structure. The same principle may also be applied to transverse corrugated bulkheads.

Regulation 7.7

1 Pipes and valves directly adjacent to a bulkhead or to a deck can be considered to be part of the bulkhead or deck, provided the separation distance is of the same order as the bulkhead or deck stiffening structure. The same applies for small recesses, drain wells, etc.

2 The provision for allowing "minor progressive flooding" is to be limited to pipes penetrating a watertight subdivision with a total cross-sectional area of not more than 710 mm² between any two watertight compartments.

Regulation 7-1 Calculation of the factor p_i

General

1 The definitions below are intended to be used for the application of part B-1 only.

1.1 In regulation 7-1, the words "compartment" and "group of compartments" are to be understood to mean "zone" and "adjacent zones".

1.2 Zone — a longitudinal interval of the ship within the subdivision length.

1.3 Room — a part of the ship, limited by bulkheads and decks, having a specific permeability.

1.4 Space — a combination of rooms.

1.5 Compartment — an onboard space within watertight boundaries.

1.6 Damage — the three dimensional extent of the breach in the ship.

1.7 A gap can be treated as a special zone defined as a discontinuity in the subdivision along the longitudinal extension of subdivision length L_s (see figure below).

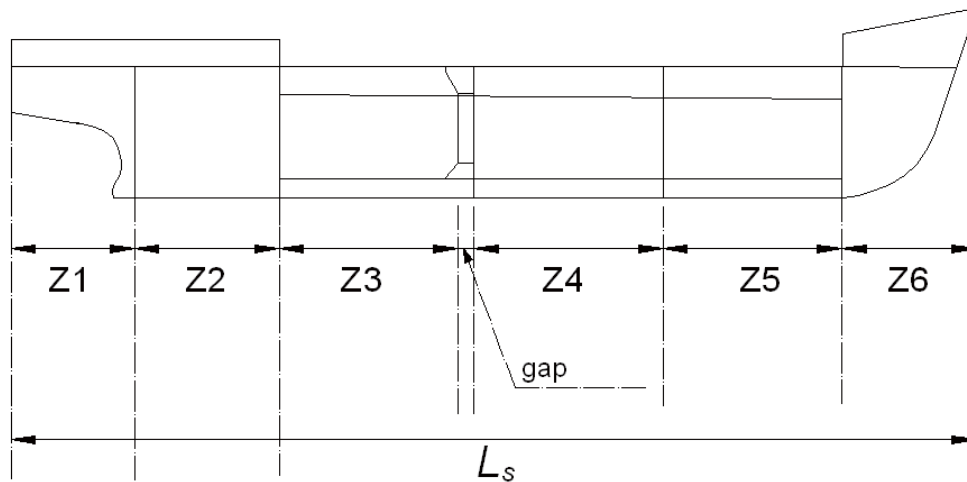

2.1 The “damage” defined in 1.6 above is to be assumed as being box-shaped. The “damage” can be defined by its tri-dimensional extension and it is assumed that the compartments located within the damage limits are open to sea. This principle is valid for one-zone damages as well as for multi-zone damages.

2.2 For the calculation of p , v , r and b only the damage is to be considered, for the calculation of the s -value the flooded space is to be considered. The figures below illustrate the difference.

Damage shown as the bold square:

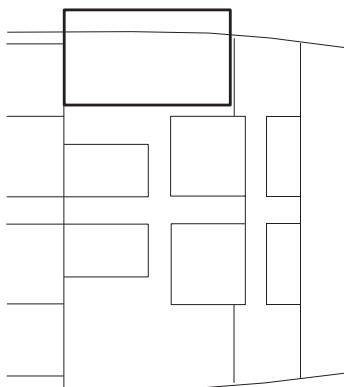

Flooded space shown below:

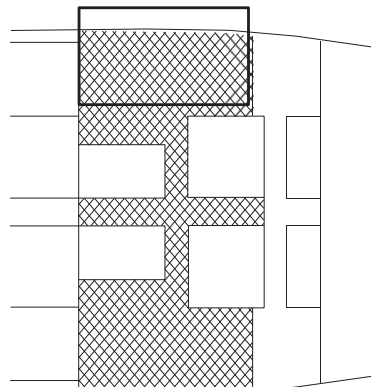

3 For one-zone damages, the gaps defined in 1.7 above are not relevant. A box-shaped damage leads to the flooding of the compartments located inside the relevant zone and the p_i values reflect correctly the damage extension on the longitudinal direction. For multi-zone damages a box-shaped damage does not only lead to the flooding of the compartments situated inside the relevant zones, but also to the flooding of the gap fitted between the relevant zones. In this case, the p_i values correspond to the extension of the damage in the longitudinal direction.

Regulation 7-1.1.1

1 The coefficients b_{11} , b_{12} , b_{21} and b_{22} are coefficients in the bi-linear probability density function on normalized damage length (J). The coefficient b_{12} is dependent on whether L_s is greater or less than L^* (i.e. 260 m); the other coefficients are valid irrespective of L_s .

Longitudinal subdivision

2 In order to prepare for the calculation of index A , the ship's subdivision length L_s is divided into a fixed discrete number of damage zones. These damage zones will determine the damage stability investigation in the way of specific damages to be calculated.

3 There are no rules for the subdividing, except that the length L_s defines the extremes for the actual hull. Zone boundaries need not coincide with physical watertight boundaries. However, it is important to consider a strategy carefully to obtain a good result (that is a large attained index A). All zones and combination of adjacent zones may contribute to the index A . In general it is expected that the more zone boundaries the ship is divided into the higher will be the attained index, but this benefit is to be balanced against extra computing time. The figure below shows different longitudinal zone divisions of the length L_s .

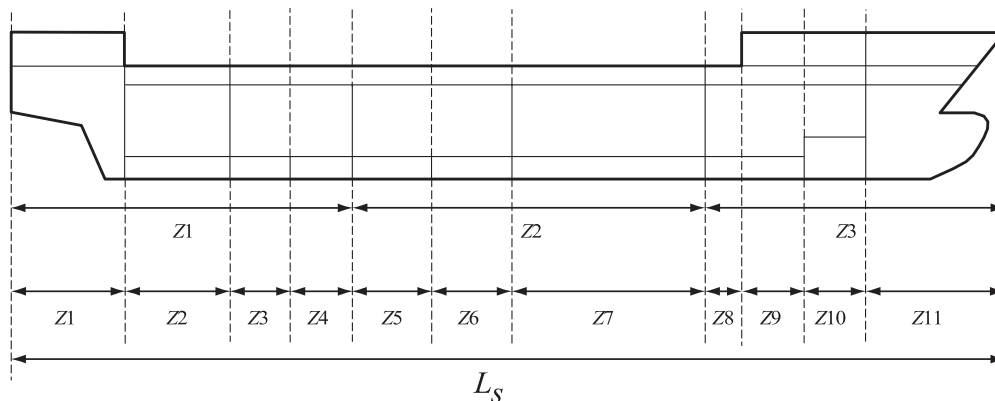

4 The first example is a very rough division into three zones of approximately the same size with limits where longitudinal subdivision is established. The probability that the ship will survive a damage in one of the three zones is expected to be low (i.e. the s -factor is low or zero) and, therefore, the total attained index A will be correspondingly low.

5 In the second example the zones have been placed in accordance with the watertight arrangement, including minor subdivision (as in double bottom, etc.). In this case there is a much better chance of obtaining higher s -factors.

6 Where transverse corrugated bulkheads are fitted, they may be treated as equivalent plane bulkheads, provided the corrugation depth is of the same order as the stiffening structure.

7 Pipes and valves directly adjacent to a transverse bulkhead can be considered to be part of the bulkhead, provided the separation distance is of the same order as the bulkhead stiffening structure. The same applies for small recesses, drain wells, etc.

8 For cases where the pipes and valves are outside the transverse bulkhead stiffening structure, when they present a risk of progressive flooding to other watertight compartments that will have influence on the overall attained index A , they are to be handled either by introducing a new damage zone and accounting for the progressive flooding to associated compartments or by introducing a gap.

9 The triangle in the figure below illustrates the possible single and multiple zone damages in a ship with a watertight arrangement suitable for a seven-zone division. The triangles at the bottom line indicate single zone damages and the parallelograms indicate adjacent zones damages.

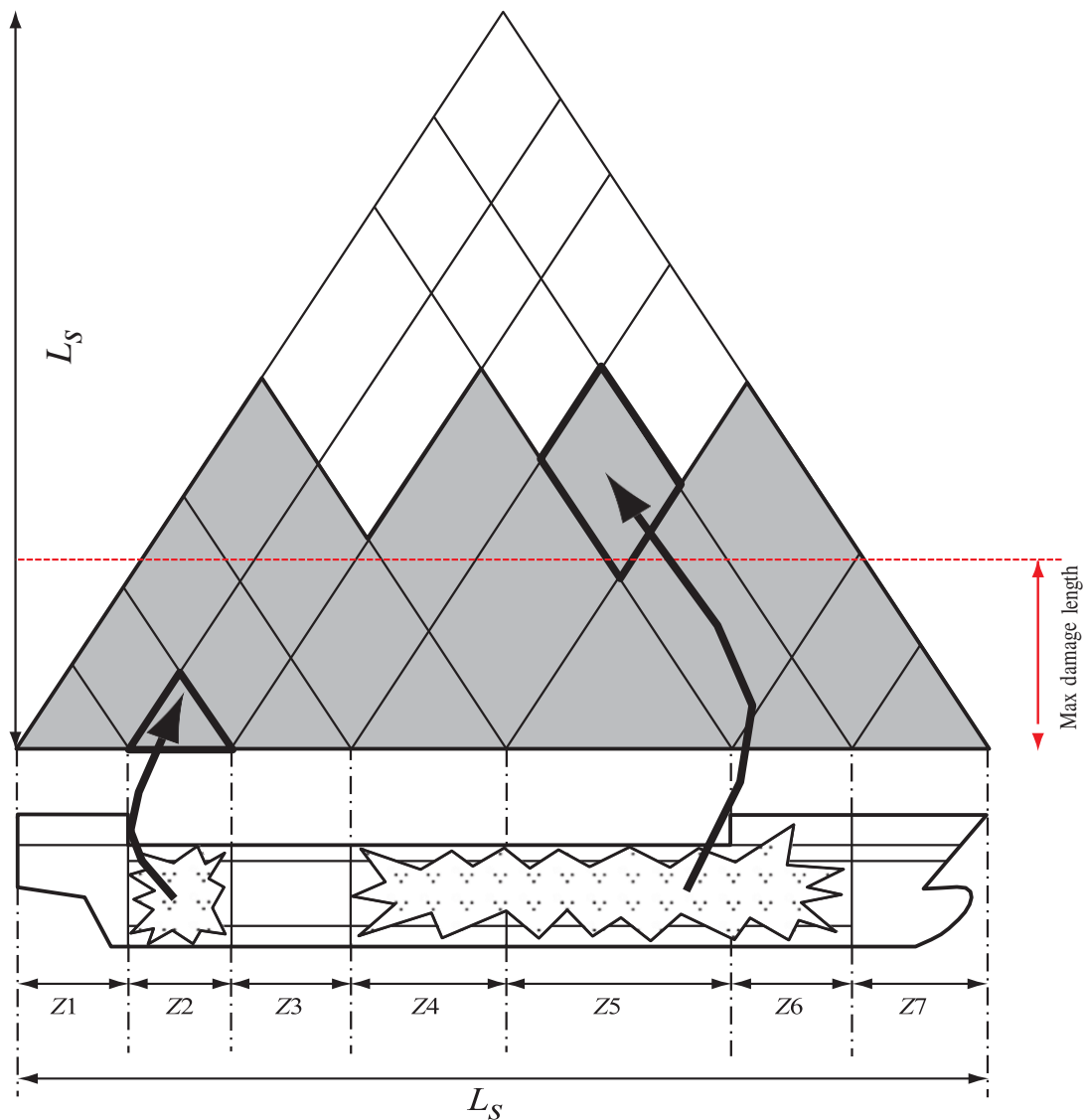

10 For single zone damages and multiple zones damages, see figure above. As an example, the triangle illustrates a damage opening the rooms in zone 2 to the sea and the parallelogram illustrates a damage where rooms in the zones 4, 5 and 6 are flooded simultaneously.

11 According to regulation 7-1.1.1, the maximum damage length equals to 60 m. The shaded area illustrates the effect of the maximum absolute damage length. The p -factor for a combination of three or more adjacent zones equals zero if the length of the combined adjacent damage zones minus the length of the foremost and the aft most damage zones in the combined damage zone is greater than the maximum damage length. Having this in mind when subdividing L_s could limit the number of zones defined to maximize the attained index A .

12 As the p -factor is related to the watertight arrangement by the longitudinal limits of damage zones and the transverse distance from the ship side to any longitudinal barrier in the zone, the following indices are introduced:

- j : the damage zone number starting with No.1 at the stern;
- n : the number of adjacent damage zones in question where j is the aft zone;
- k : the number of a particular longitudinal bulkhead as a barrier for transverse penetration in a damage zone counted from shell towards the centreline. The shell has No.0;
- K : total number of transverse penetration boundaries;
- $P_{j,n,k}$: the p -factor for a damage in zone j and nest $(n-1)$ zones forward of j damaged to the longitudinal bulkhead k .

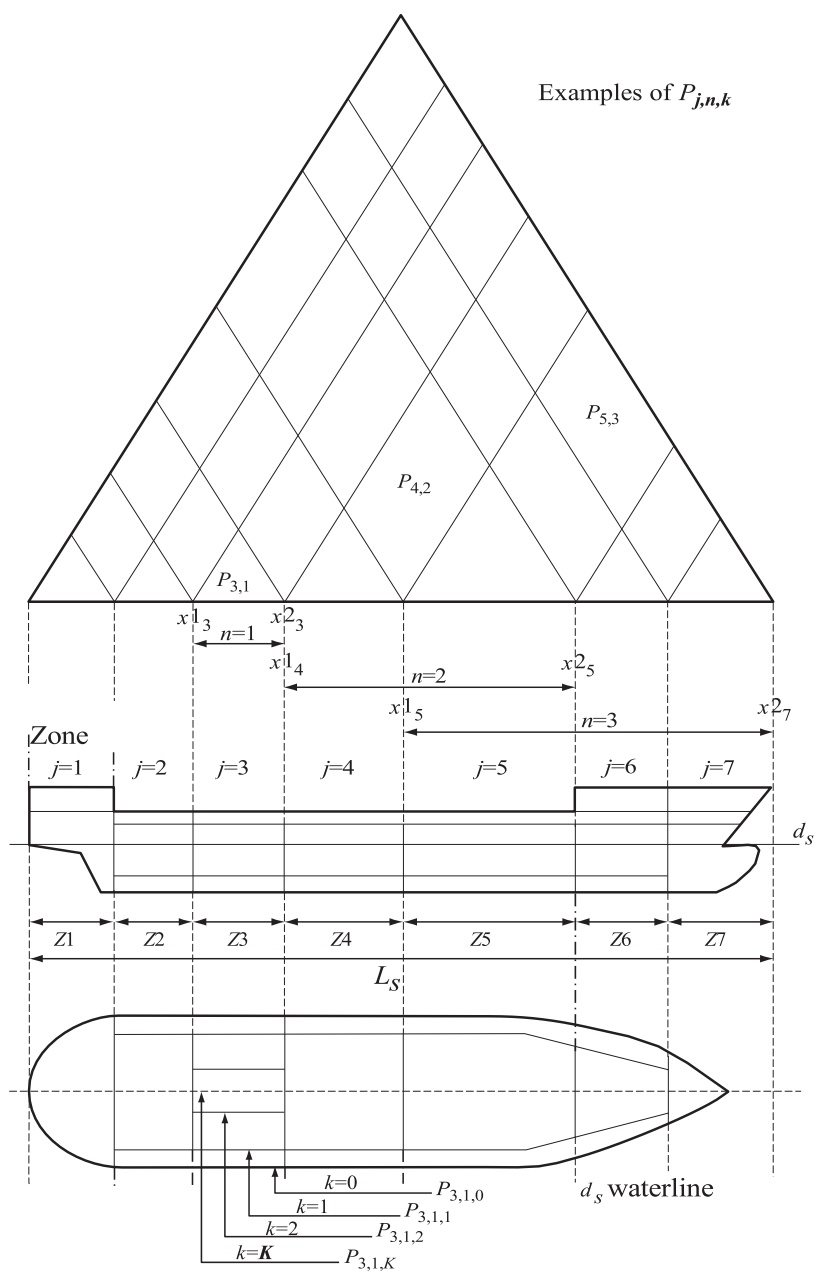

Pure longitudinal subdivision

Single damage zone, pure longitudinal subdivision:

$$p_{j,1} = p(x1_j, x2_j)$$

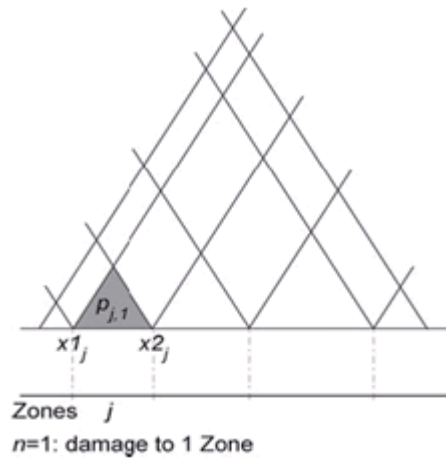

Two adjacent zones, pure longitudinal subdivision:

$$p_{j,2} = p(x1_j, x2_{j+1}) - p(x1_j, x2_j) - p(x1_{j+1}, x2_{j+1})$$

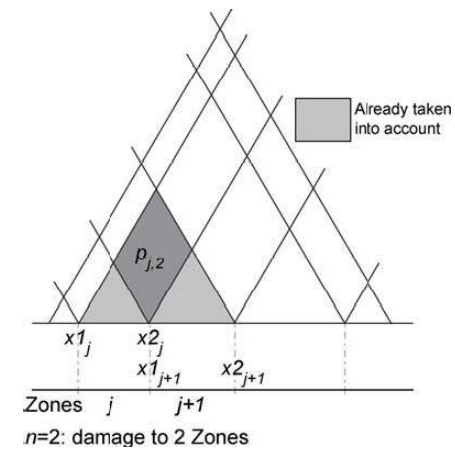

Three or more adjacent zones, pure longitudinal subdivision:

$$p_{j,n} = p(x1_j, x2_{j+n-1}) - p(x1_j, x2_{j+n-2}) - p(x1_{j+1}, x2_{j+n-1}) + p(x1_{j+1}, x2_{j+n-2})$$

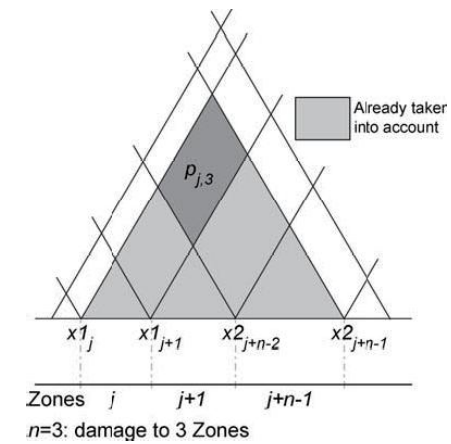

Regulation 7-1.1.2

Transverse subdivision in a damage zone

1 Damage to the hull in a specific damage zone may just penetrate the ship's watertight hull or penetrate further towards the centreline. To describe the probability of penetrating only a wing compartment, a probability factor r is used, based mainly on the penetration depth b . The value of r is equal to 1, if the penetration depth is $B/2$ where B is the maximum breadth of the ship at the deepest subdivision draught d_s , and $r = 0$ if $b = 0$.

2 The penetration depth b is measured at level deepest subdivision draught d_s as a transverse distance from the ship side right-angled to the centreline to a longitudinal barrier.

3 Where the actual watertight bulkhead is not a plane parallel to the shell, b is to be determined by means of an assumed line, dividing the zone to the shell in a relationship b_1/b_2 with $1/2 \leq b_1/b_2 \leq 2$.

4 Examples of such assumed division lines are illustrated in the figure below. Each sketch represents a single damage zone at a water line plane level d_s and the longitudinal bulkhead represents the outermost bulkhead position below $d_s + 12.5$ m.

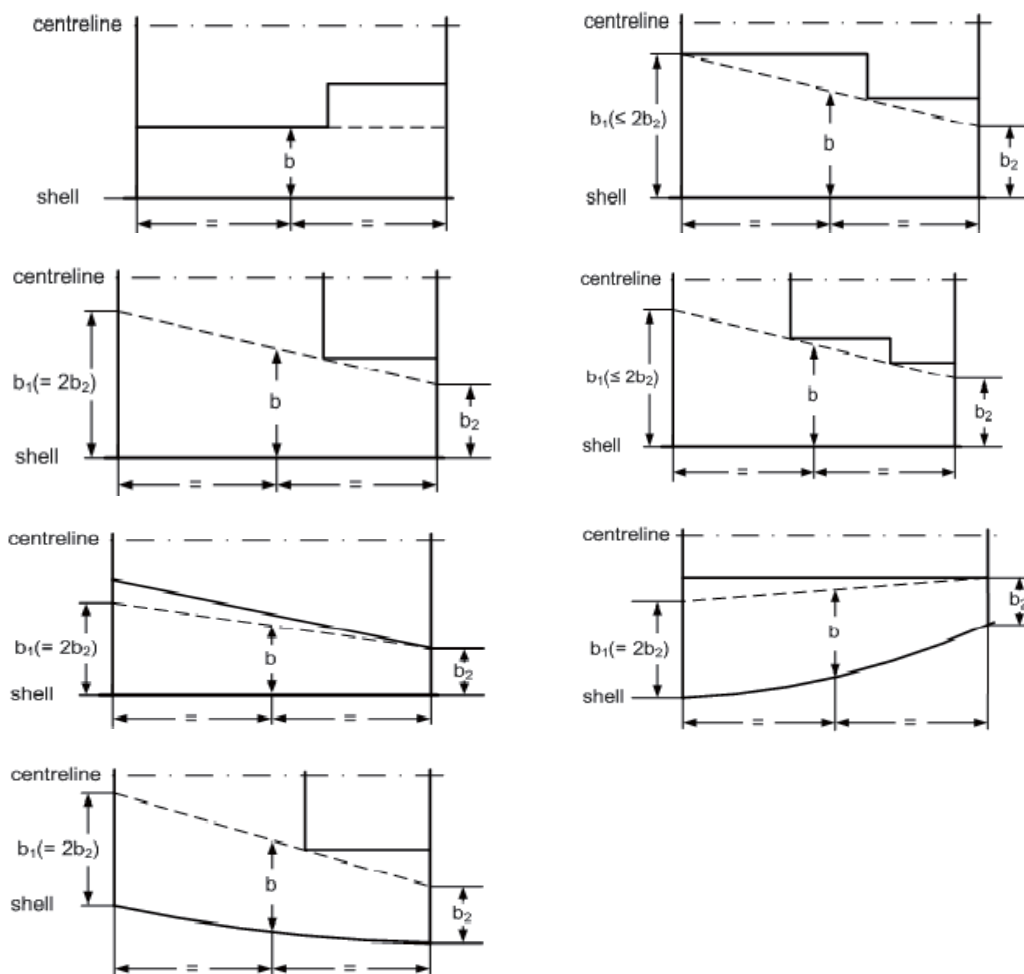

5 In calculating r -values for a group of two or more adjacent compartments, the b -value is common for all compartments in that group, and equal to the smallest b -value in that group:

$$b = \min \{b_1, b_2, \dots, b_n\}$$

where: n = number of wing compartments in that group;

b_1, b_2, \dots, b_n = mean values of b for individual wing compartments contained in the group.

Accumulating p

6 The accumulated value of p for one zone or a group of adjacent zones is determined by:

$$p_{j,n} = \sum_{k=1}^{k=K_{j,n}} p_{j,n,k}$$

where $K_{j,n} = \sum_j^{j+n-1} K_j$ the total number of b_k 's for the adjacent zones in question.

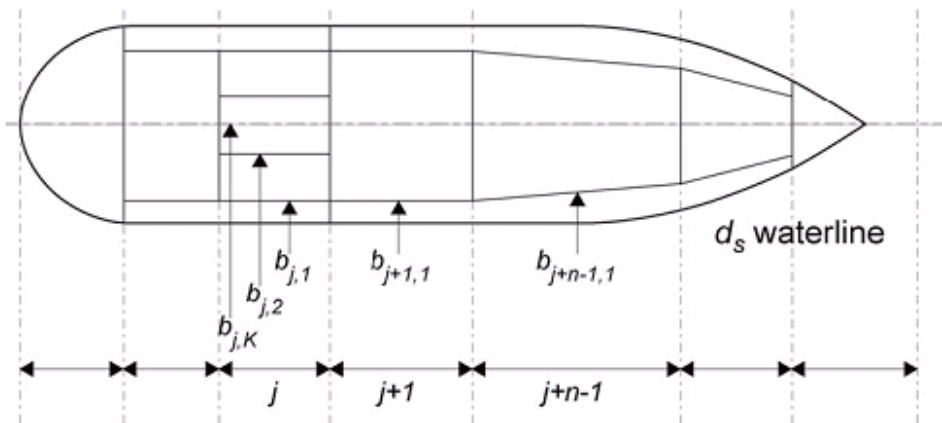

7 The figure above illustrates b 's for adjacent zones. The zone j has two penetration limits and one to the centre, the zone $j+1$ has one b and the zone $j+n-1$ has one value for b . The multiple zones will have $(2+1+1)$ four values of b , and sorted in increasing order they are:

$$(b_{j,1}; b_{j+1,1}; b_{j+n-1,1}; b_{j,2}; b_K)$$

8 Because of the expression for $r(x_1, x_2, b)$ only one b_K is to be considered. To minimize the number of calculations, b 's of the same value may be deleted. As $b_{j,1} = b_{j+1,1}$ the final b 's will be $(b_{j,1}; b_{j+n-1,1}; b_{j,2}; b_K)$.

Examples of multiple zones having a different b

9 Examples of combined damage zones and damage definitions are given in the figures below. Compartments are identified by R10, R12, etc.

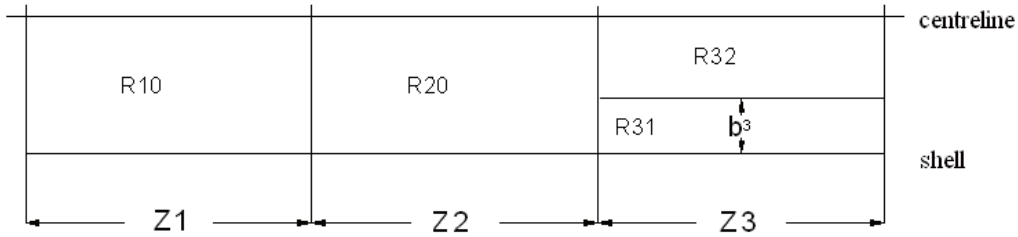

Figure: Combined damage of zones 1 + 2 + 3 includes a limited penetration to b_3 , taken into account generating two damages:

- 1) to b_3 with R10, R20 and R31 damaged;
- 2) to $B/2$ with R10, R20, R31 and R32 damaged.

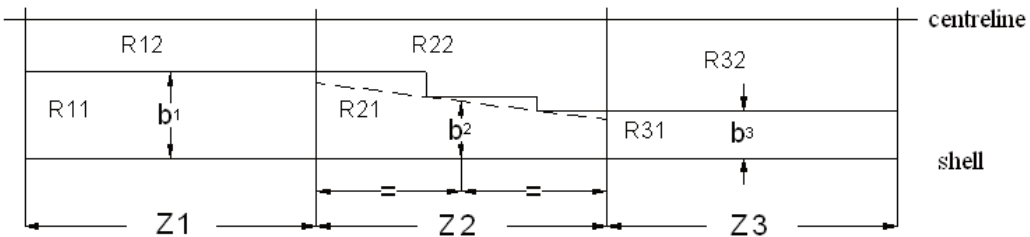

Figure: Combined damage of zones 1 + 2 + 3 includes 3 different limited damage penetrations generating four damages:

- 1) to b_3 with R11, R21 and R31 damaged;
- 2) to b_2 with R11, R21, R31 and R32 damaged;
- 3) to b_1 with R11, R21, R31, R32, and R22 damaged;
- 4) to $B/2$ with R11, R21, R31, R32, R22 and R12 damaged.

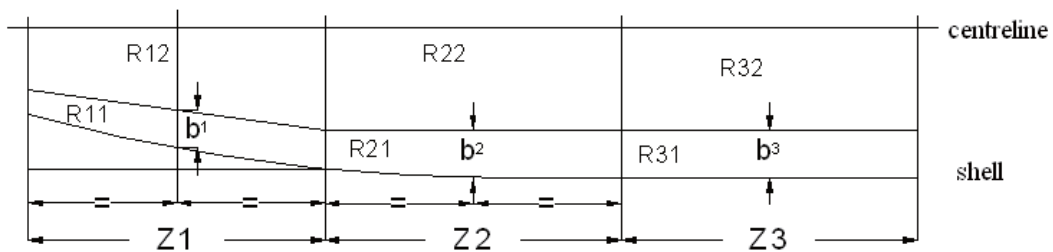
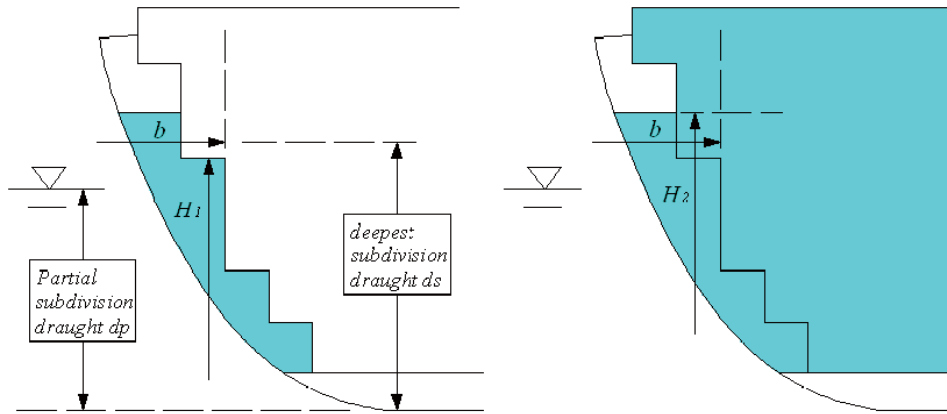

Figure: Combined damage of zone 1 + 2 + 3 including 2 different limited damage penetrations ($b_1 < b_2 = b_3$) generating three damages:

- 1) to b_1 with R11, R21 and R31 damaged;
- 2) to b_2 with R11, R21, R31 and R12, damaged;
- 3) to $B/2$ with R11, R21, R31, R12, R22 and R32 damaged.

10 A damage having a transverse extent b and a vertical extent H_2 leads to the flooding of both wing compartment and hold; for b and H_1 only the wing compartment is flooded. The figure below illustrates a partial subdivision draught damage.



11 The same is valid if b -values are calculated for arrangements with sloped walls.

12 Pipes and valves directly adjacent to a longitudinal bulkhead can be considered to be part of the bulkhead, provided the separation distance is of the same order as the bulkhead stiffening structure. The same applies for small recesses, drain wells, etc.

Regulation 7-2 Calculation of the factor s_i

General

1 Initial condition — an intact loading condition to be considered in the damage analysis described by the mean draught, vertical centre of gravity and the trim; or alternative parameters from where the same may be determined (ex. displacement, GM and trim). There are three initial conditions corresponding to the three draughts d_s , d_p and d_t .

2 Immersion limits — immersion limits are an array of points that are not to be immersed at various stages of flooding as indicated in regulations 7-2.5.2 and 7-2.5.3.

3 Openings — all openings need to be defined: both weathertight and unprotected. Openings are the most critical factor to preventing an inaccurate index A . If the final waterline immerses the lower edge of any opening through which progressive flooding takes place, the factor “ s ” may be recalculated taking such flooding into account. However, in this case the s value is also to be calculated without taking into account progressive flooding and corresponding opening. The smallest s value is to be retained for the contribution to the attained index.

Regulation 7-2.1

1 In cases where the GZ curve may include more than one “range” of positive righting levers for a specific stage of flooding, only one continuous positive “range” of the GZ curve may be used within the allowable range/heel limits for calculation purposes. Different stages of flooding may not be combined in a single GZ curve.

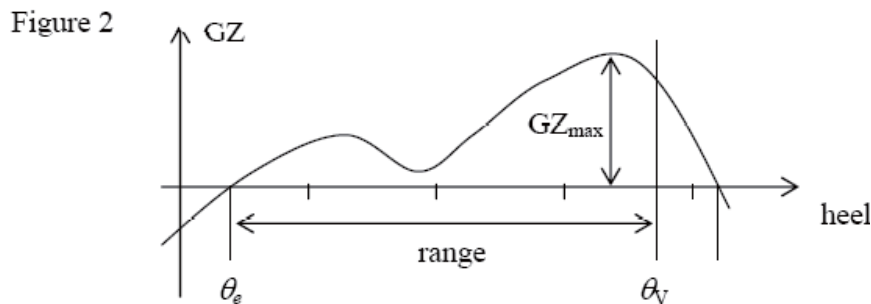
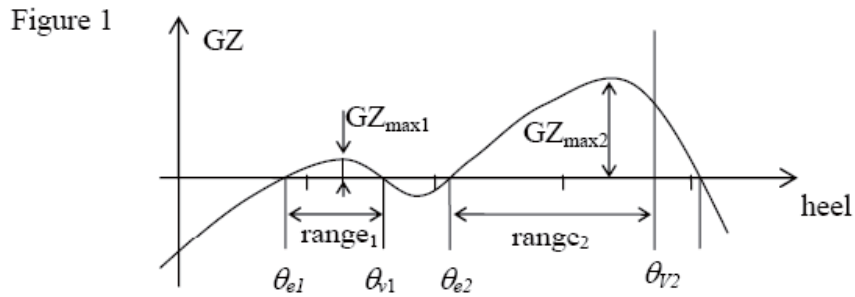

2 In figure 1, the s -factor may be calculated from the heel angle, range and corresponding GZ_{\max} of the first or second “range” of positive righting levers. In figure 2, only one s -factor can be calculated.

Regulation 7-2.2

Intermediate stages of flooding

1 The case of instantaneous flooding in unrestricted spaces in way of the damage zone does not require intermediate stage flooding calculations. Where intermediate stages of flooding calculations are necessary in connection with progressive flooding, they are to reflect the sequence of filling as well as filling level phases. Calculations for intermediate stages of flooding are to be performed whenever equalization is not instantaneous, i.e. equalization is of a duration greater than 60 s. Such calculations consider the progress through one or more floodable (non-watertight) spaces. Bulkheads surrounding refrigerated spaces, incinerator rooms and longitudinal bulkheads fitted with non-watertight doors are typical examples of structures that may significantly slow down the equalization of main compartments.

Flooding boundaries

2 If a compartment contains decks, inner bulkheads, structural elements and doors of sufficient tightness and strength to seriously restrict the flow of water, for intermediate stage flooding calculation purposes it is to be divided into corresponding non-watertight spaces. It is assumed that the non-watertight divisions considered in the calculations are limited to “A” class fire-rated bulkheads and do not apply to “B” class fire-rated bulkheads normally used in accommodation areas (e.g., cabins and corridors). This guidance also relates to regulation 4.4.

Sequential flooding computation

3 For each damage scenario, the damage extent and location determine the initial stage of flooding. Calculations are to be performed in stages, each stage comprising of at least two intermediate filling phases in addition to the full phase per flooded space. Unrestricted spaces in way of damage are to be considered as flooded immediately. Every subsequent stage involves all connected spaces being flooded simultaneously until an impermeable boundary or final equilibrium is reached. If due to the configuration of the subdivision in the ship it is expected that other intermediate stages of flooding are more onerous, then those are to be investigated.

Cross-flooding/equalization

4 In general, cross-flooding is meant as a flooding of an undamaged space on the other side of the ship to reduce the heel in the final equilibrium condition.

5 The cross-flooding time is to be calculated in accordance with the Recommendation on a standard method for evaluating cross-flooding arrangements (resolution MSC.245(83)). If complete fluid equalization occurs in 60 s or less, it is to be treated as instantaneous and no further calculations need to be carried out. Additionally, in cases where $s_{final} = 1$ is achieved in 60 s or less, but equalization is not complete, instantaneous flooding may also be assumed if s_{final} will not become reduced. In any cases where complete fluid equalization exceeds 60 s, the value of $s_{intermediate}$ after 60 s is the first intermediate stage to be considered. Only passive open cross-flooding arrangements without valves are to be considered effective for instantaneous flooding cases.

6 If complete fluid equalization can be finalized in 10 min or less, the assessment of survivability can be carried out for passenger ships as the smallest values of $s_{intermediate}$ or s_{final} .

7 In case the equalization time is longer than 10 min, s_{final} is calculated for the floating position achieved after 10 min of equalization. This floating position is computed by calculating the amount of flood water according to resolution MSC.245(83) using interpolation, where the equalization time is set to 10 min, i.e. the interpolation of the flood water volume is made between the case before equalization ($T = 0$) and the total calculated equalization time.

8 In any cases where complete fluid equalization exceeds 10 min, the value of s_{final} used in the formula in regulation 7-2.1.1 is to be the minimum of s_{final} at 10 min or at final equalization.

Cargo ships

9 If the Administration considers that the stability in intermediate stages of flooding in a cargo ship may be insufficient, it may require further investigation thereof.

Regulation 7-2.4

The displacement is the intact displacement at the subdivision draught in question (d_s , d_p and d_l).

Regulation 7-2.4.1.1

The beam B used in this paragraph means breadth as defined in regulation 2.8.

Regulation 7-2.4.1.2

The parameter *A* (projected lateral area) used in this paragraph does not refer to the attained subdivision index.

Regulation 7-2.5

In cargo ships where cross-flooding devices are fitted, the safety of the ship is to be maintained in all stages of flooding. The Administration may request for this to be demonstrated. Cross-flooding equipment, if installed, is to have the capacity to ensure that the equalization takes place within 10 min.

Regulation 7-2.5.2.1

Unprotected openings

1 The flooding angle will be limited by immersion of such an opening. It is not necessary to define a criterion for non-immersion of unprotected openings at equilibrium, because if it is immersed, the range of positive *GZ* limited to flooding angle will be zero so “*s*” will be equal to zero.

2 An unprotected opening connects two rooms or one room and the outside. An unprotected opening will not be taken into account if the two connected rooms are flooded or none of these rooms are flooded. If the opening is connected to the outside, it will not be taken into account if the connected compartment is flooded. An unprotected opening does not need to be taken into account if it connects a flooded room or the outside to an undamaged room, if this room will be considered as flooded in a subsequent stage.

Openings fitted with a weathertight mean of closing (“weathertight openings”)

3 The survival “*s*” factor will be “0” if any such point is submerged at a stage which is considered as “final”. Such points may be submerged during a stage or phase which is considered as “intermediate”, or within the range beyond equilibrium.

4 If an opening fitted with a weathertight means of closure is submerged at equilibrium during a stage considered as intermediate, it is to be demonstrated that this weathertight means of closure can sustain the corresponding head of water and that the leakage rate is negligible.

5 These points are also defined as connecting two rooms or one room and the outside, and the same principle as for unprotected openings is applied to take them into account or not. If several stages have to be considered as “final”, a “weathertight opening” does not need to be taken into account if it connects a flooded room or the outside to an undamaged room if this room will be considered as flooded in a successive “final” stage.

Regulation 7-2.5.2.2

1 Partial immersion of the bulkhead deck may be accepted at final equilibrium. This provision is intended to ensure that evacuation along the bulkhead deck to the vertical escapes will not be impeded by water on that deck. A “horizontal evacuation route” in the context of this regulation means a route on the bulkhead deck connecting spaces located on and under this deck with the vertical escapes from the bulkhead deck required for compliance with SOLAS chapter II-2.

2 Horizontal evacuation routes on the bulkhead deck include only escape routes (designated as category 2 stairway spaces according to SOLAS regulation II-2/9.2.2.3 or as category 4 stairway spaces according to SOLAS regulation II-2/9.2.2.4 for passenger ships carrying not more than 36 passengers) used for the evacuation of undamaged spaces. Horizontal evacuation routes do not include corridors (designated as category 3 corridor spaces according to SOLAS regulation II-2/9.2.2.3 or as category 2 corridor spaces according to SOLAS regulation II-2/9.2.2.4 for passenger ships carrying not more than 36 passengers) within the damaged space. No part of a horizontal evacuation route serving undamaged spaces is to be immersed.

3 $s_i = 0$ where it is not possible to access a stair leading up to the embarkation deck from an undamaged space as a result of flooding to the “stairway” or “horizontal stairway” on the bulkhead deck.

4 Horizontal escapes situated in way of the damage extent may remain effective, therefore s_i need not be taken as zero. Contributions to the attained index A may still be gained.

Regulation 7-2.5.3.1

1 The purpose of this paragraph is to provide an incentive to ensure that evacuation through a vertical escape will not be obstructed by water from above. The paragraph is intended for smaller emergency escapes, typically hatches, where fitting of a watertight or weathertight means of closure would otherwise exclude them from being considered as flooding points.

2 Since the probabilistic regulations do not require that the watertight bulkheads be carried continuously up to the bulkhead deck, care is to be taken to ensure that evacuation from intact spaces through flooded spaces below the bulkhead deck will remain possible, for instance by means of a watertight trunk.

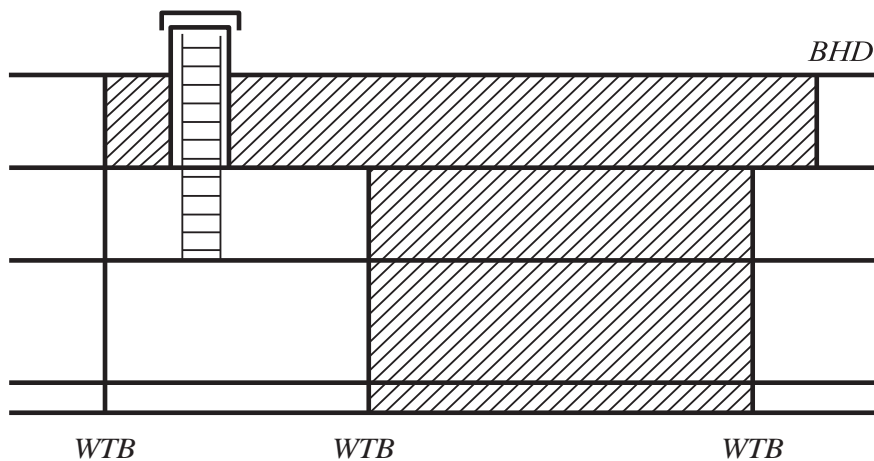

Regulation 7-2.6

1 When considering the buoyancy of timber deck cargo at partial timber subdivision draught and deepest timber subdivision draught for ships assigned with timber load lines, the upper deck may be regarded as a horizontal subdivision which is assumed to limit the vertical extent of flooding. For damage extending above the upper deck the timber deck cargo buoyancy in way of the damage zone is to be ignored.

2 The sketches in the figure illustrate the connection between position of watertight decks in the reserve buoyancy area and the use of factor v for damages below these decks.

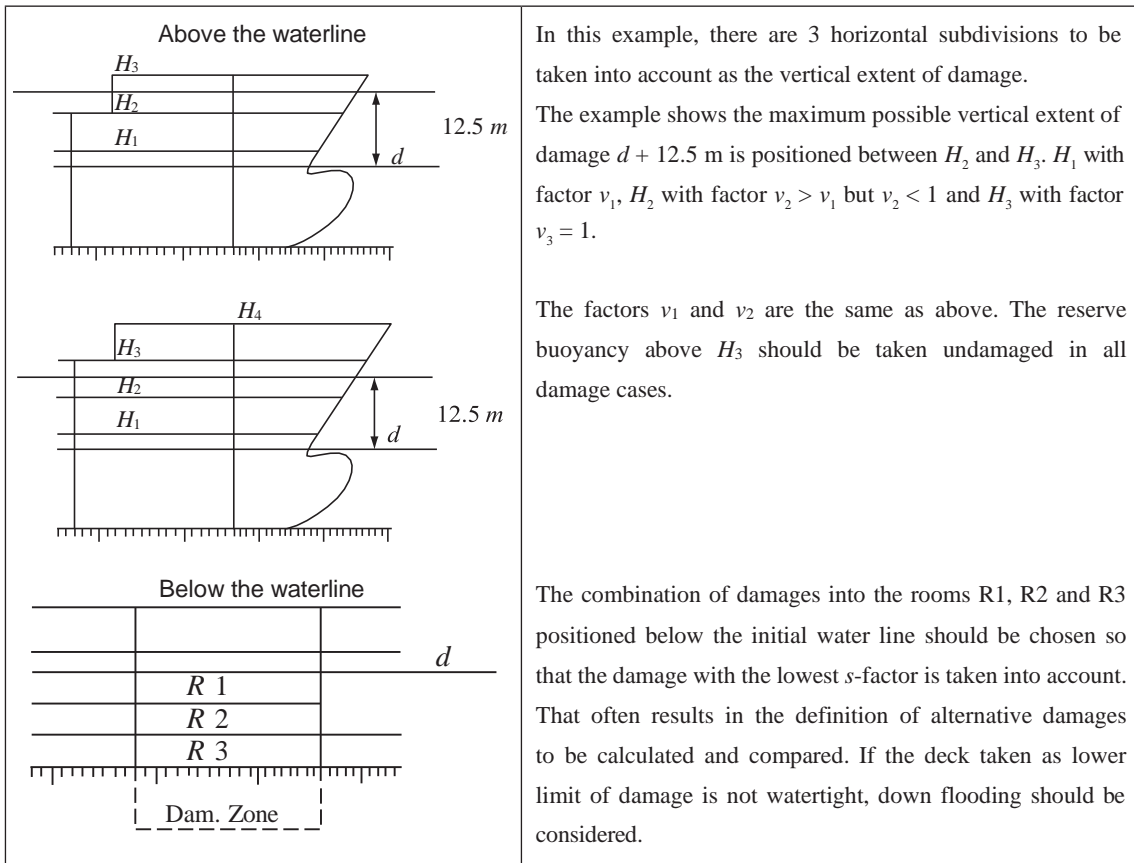

Regulation 7-2.6.1

The parameters x_1 and x_2 are the same as parameters x_1 and x_2 used in regulation 7-1.

Regulation 7-3 — Permeability

Regulation 7-3.2

The following additional cargo permeabilities may be used:

Spaces	Permeability at draught d_s	Permeability at draught d_p	Permeability at draught d_t
Timber cargo in holds	0.35	0.70	0.95
Wood chip cargo	0.60	0.70	0.95

75 percent of the volume of timber deck cargo may be added to the reserve buoyancy.

Regulation 7-3.3

1 Concerning the use of other figures for permeability “if substantiated by calculations”, such permeabilities are to reflect the general conditions of the ship throughout its service life rather than specific loading conditions.

2 This paragraph allows for the recalculation of permeabilities. This is only to be considered in cases where it is evident that there is a major discrepancy between the values shown in the regulation and the real values. It is not designed for improving the attained value of a deficient ship of regular type by the modification of chosen spaces in the ship that are known to provide significantly onerous results. All proposals are to be considered on a case-by-case basis by the Administration and are to be justified with adequate calculations and arguments.

Regulation 8 Special requirements concerning passenger ship stability

Regulations 8.3.2 to 8.3.5

The number of persons carried, which is specified in these paragraphs, equals the total number of persons the ship is permitted to carry (and not $N = N_1 + 2 N_2$ as defined in regulation 6).

Regulation 8-1 System capabilities after a flooding casualty on passenger ships

Regulation 8-1.2

1 In the context of this regulation, “compartment” has the same meaning as defined under regulation 7-1 of the Guidelines (i.e. an onboard space within watertight boundaries).

2 The purpose of the paragraph is to prevent any flooding of limited extent from immobilizing the ship. This principle is to be applied regardless of how the flooding might occur. Only flooding below the bulkhead deck need be considered.

Part B-2 SUBDIVISION, WATERTIGHT AND WEATHERTIGHT INTEGRITY

Regulation 9 Double bottoms in passenger ships and cargo ships other than tankers

Regulation 9.1

1 This regulation is intended to minimize the impact of flooding from a minor grounding. Special attention is to be paid to the vulnerable area at the turn of the bilge. When justifying a deviation from fitting an inner bottom an assessment of the consequences of allowing a more extensive flooding than reflected in the regulation is to be provided.

2 Except as provided in regulations 9.3 and 9.4, parts of the double bottom not extended for the full width of the ship as required by regulation 9.1 are to be considered an unusual arrangement for the purpose of this regulation and are to be handled in accordance with regulation 9.7.

Regulation 9.2

If an inner bottom is located higher than the partial subdivision draught d_p , this is to be considered an unusual arrangement and is to be handled in accordance with regulation 9.7.

Regulation 9.6

1 Any part of a passenger ship or a cargo ship where a double bottom is omitted in accordance with regulation 9.1, 9.4 or 9.5 is to be capable of withstanding bottom damages, as specified in regulation 9.8. The intent of this provision is to specify the circumstances under which the Administration is to require calculations, which damage extents to assume and what survival criteria to apply when double bottoms are not fitted.

2 The definition of “watertight” in regulation 2.17 implies that the strength of inner bottoms and other boundaries assumed to be watertight is to be verified if they are to be considered effective in this context.

Regulation 9.7

The reference to a “plane” in regulation 9.2 does not imply that the surface of the inner bottom may not be stepped in the vertical direction. Minor steps and recesses need not be considered unusual arrangements for the purpose of this paragraph as long as no part of the inner bottom is located below the reference plane. Discontinuities in way of wing tanks are covered by regulation 9.4.

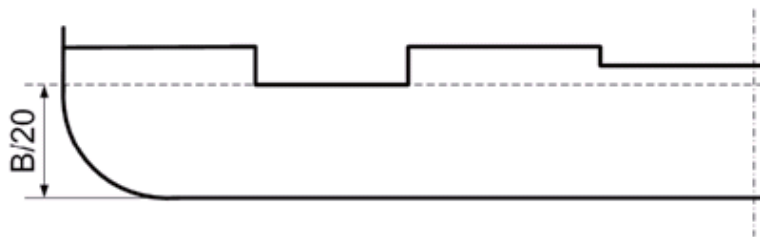

Regulation 9.8

1 The term “all service conditions” used in this paragraph means the three loading conditions used to calculate the attained subdivision index A .

2 The damage extents specified in this paragraph are to be applied to all parts of the ship where no double bottom is fitted, as permitted by regulations 9.1, 9.4 or 9.5, and include any adjacent spaces located within the extent of damage. Small wells in accordance with regulation 9.3 do not need to be considered damaged even if within the extent of the damage. Possible positions of the damages are shown in an example below (parts of the ship not fitted with a double bottom are shaded; the damages to be assumed are indicated by boxes).

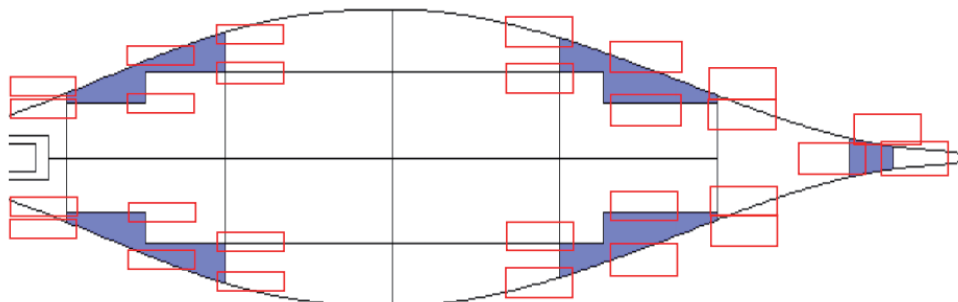

Regulation 9.9

1 For the purpose of identifying “large lower holds”, horizontal surfaces having a continuous deck area greater than approximately 30% in comparison with the waterplane area at subdivision draught are to be taken to be located anywhere in the affected area of the ship. For the alternative bottom damage calculation, a vertical extent of $B/10$ or 3 m, whichever is less, is to be assumed.

2 The increased minimum double bottom height of not more than $B/10$ or 3 m, whichever is less, for passenger ships with large lower holds, is applicable to holds in direct contact with the double bottom. Typical arrangements of ro-ro passenger ships may include a large lower hold with additional tanks between the double bottom and the lower hold, as shown in the figure below. In such cases, the vertical position of the double bottom required to be $B/10$ or 3 m, whichever is less, is to be applied to the lower hold deck, maintaining the required double bottom height of $B/20$ or 2 m, whichever is less (but not less than 760 mm).

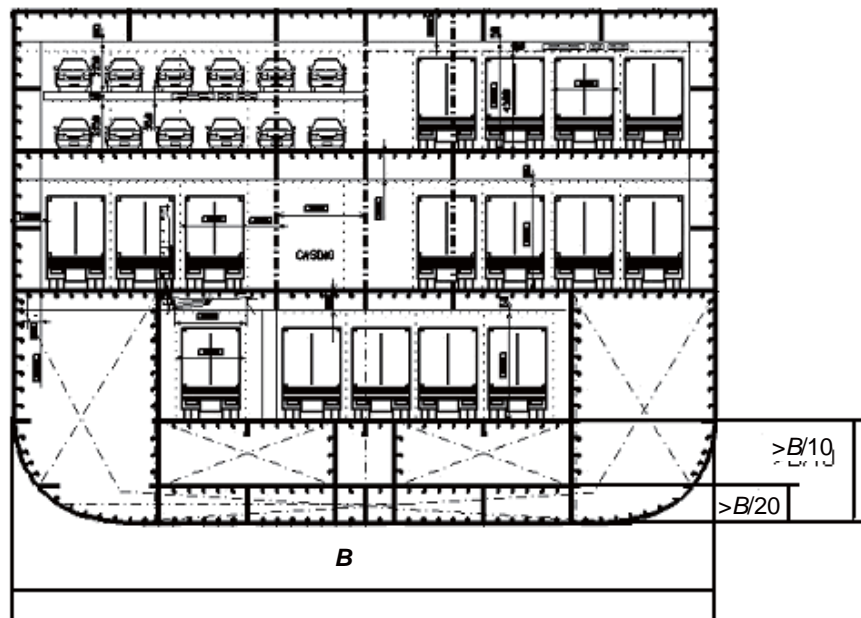

Regulation 10 Construction of watertight bulkheads

Regulation 10.1

For the treatment of steps in the bulkhead deck of passenger ships, see regulation 13. For the treatment of steps in the freeboard deck of cargo ships, see regulation 13-1.

Regulation 12 Peak and machinery space bulkheads, shaft tunnels, etc.

Position of the forward perpendicular

On some ships the position of the forward perpendicular had been altered by the addition of a steel plate or very light steel structure between the stem and the bulbous bow, which altered the position of the intersection of the stem with the waterline thereby altering the position of the forward measuring point, which is relevant to the position of collision bulkhead and ramp. In the case of such ships, it resulted in bulkheads and bow ramps, which in the first instance would appear to be wrongly located before these modifications, being deemed by Administrations to be correctly located. Such a practice was not within the spirit of this regulation. For the purpose of this regulation, interpretation of the position of the forward perpendicular is as follows:

“The forward perpendicular is the same as that defined in regulation 2.7. The stem is the contour of the outer surface of the hull at the forward end and excludes any appendages except a bulbous bow.”

Regulation 12.6 - Bow door and extension of the collision bulkhead

Where a long forward superstructure is fitted, the collision bulkhead is to be extended weathertight to the deck next above the bulkhead deck. The extension need not be fitted directly above the bulkhead below provided that all parts of the extension, including any part of the ramp attached to it are located within the limits prescribed in paragraph 1 or 2 of, with the exception permitted by paragraph 7 in, regulation II-1/12 and that the part of the deck which forms the step is made effectively weathertight (namely, the extension above the bulkhead deck and the bulkhead may form the step together). The extension is to be so arranged as to preclude the possibility of the bow door or ramp, where fitted, causing damage to it in the case of damage to, or detachment of, a bow door or any part of the ramp.

Regulation 12.10 - Enclosure of stern tubes

For cargo ships, a stern tube enclosed in a watertight space of moderate volume, such as an aft peak tank, where the inboard end of the stern tube extends through the aft peak/engine room watertight bulkhead into the engine room is considered to be an acceptable solution satisfying the requirement of this regulation, provided the inboard end of the stern tube is effectively sealed at the aft peak/engine room bulkhead by means of an approved watertight/oiltight gland system.

Regulation 13 Openings in watertight bulkheads below the bulkhead deck in passenger ships

General — Steps in the bulkhead deck

1 If the transverse watertight bulkheads in a region of the ship are carried to a higher deck which forms a vertical step in the bulkhead deck, openings located in the bulkhead at the step may be considered as being located above the bulkhead deck. Such openings are then to comply with regulation 17 and are to be taken into account when applying regulation 7-2.

2 All openings in the shell plating below the upper deck throughout that region of the ship are to be treated as being below the bulkhead deck and the provisions of regulation 15 are to be applied. See figure below.

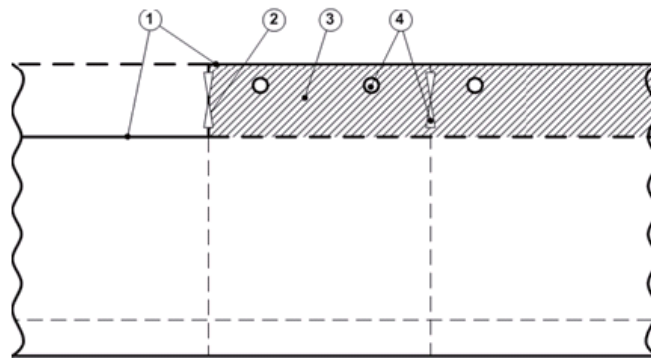

- | | |
|-----------------|---|
| 1 Bulkhead deck | 2 Considered as located above the bulkhead deck |
| 3 Ship's side | 4 Considered as located below the bulkhead deck |

General — Watertight doors and their controls, indication and alarms

1 Application

- (1) The provisions hereunder do not apply to doors located in way of the internal watertight subdivision boundaries and the external watertight boundaries above equilibrium or intermediate waterplanes.
- (2) In addition to the watertight doors specified in SOLAS Chapter II-1, the provisions hereunder also apply to those specified in ICLL, MARPOL, IBC and IGC or other mandatory stability requirements. However, the provisions do not apply to the watertight doors required by HSC Code.
- (3) Doors in watertight bulkheads of small cargo ships, not subject to any statutory subdivision and damage stability requirements, may be hinged quick acting doors arranged to open out of the major space protected. They are to have notices affixed to each side stating, "To be kept closed at sea".

2 Definitions

Definitions relating to watertight, equilibrium waterplane, intermediate waterplane, sliding door, rolling door and hinged door are to be specified.

3 Operation mode, location and outfitting

- (1) Doors may be divided into the following categories based on the frequency of use whilst at sea: (a) normally closed; (b) permanently closed; (c) normally open; (d) used. They may also be divided into the following categories based on the type: (a) power operated, sliding or rolling (POS); (b) power operated, hinged (POH); (c) sliding or rolling (S); (d) hinged (H).
- (2) Doors are to be capable of being opened and closed by hand (and by power, where applicable) locally, from either side of the doors. Doors are to be capable of being remotely closed by power from the bridge (or other position), where remote control system is fitted.
- (3) Where shown in Table 1, position indicators are to be provided at all remote operating positions as well as locally, on both sides of the doors. Doors which are to be capable of being remotely controlled are to be provided with an audible alarm (and visual signals).

(4) Doors which are normally closed at sea but not provided with means of remote closure, are to have notices fixed to both sides of the doors stating, To be kept closed at sea. Doors which are to be permanently closed at sea are to have notices fixed to both sides stating, “Not to be opened at sea”.

4 Testing

(1) Doors which become immersed by an equilibrium or intermediate waterplane, are to be subjected to a hydrostatic pressure test before being installed onboard. For large doors intended for use in the watertight subdivision boundaries of cargo spaces, structural analysis may be accepted in lieu of pressure testing. Where such doors utilize gasket seals, a prototype pressure test to confirm that the compression of the gasket material is capable of accommodating any deflection, revealed by the structural analysis, is to be carried out.

(2) The head of water used for the pressure test is to correspond to the bulkhead deck or freeboard deck, as applicable, or to the most unfavourable damage waterplane.

(3) Leakage criteria: (a) doors with gaskets, no leakage; (b) doors with metallic sealing, maximum leakage 1 liter/min; (c) for pressure tests on large doors located in cargo spaces employing gasket seals or guillotine doors located in conveyor tunnels, acceptable leakage rate is:

$$\text{Leakage rate (liter/min)} = (P + 4.572) h^3/6568$$

where: P = perimeter of door opening, in m;
 h = test head of water, in m.

Table 1 Internal Doors in Watertight Bulkheads in Cargo Ships and Passenger Ships

Position relative to equilibrium or intermediate waterplane	1. Frequency of use whilst at sea	2. Type	3. Remote control ^①	4. Indication locally and on bridge ^①	5. Audible alarm ^①	6. Notice	7. Comments	8. Regulation
I. Passenger Ships								
A. At or below	Norm. Closed	POS	Yes	Yes	Yes	No	Certain doors may be left open, see SOLAS II-1/22.4	SOLAS II-1/22.1, 3&4
	Perm. Closed	S, H	No	No	No	Yes	see Notes 1 + 4	SOLAS II-1/13.9.1&2, II-1/22.6
B. Above	Norm. open	POS, POH	Yes	Yes	Yes	No		SOLAS II-1/22.4, II-1/17.1 MSC/Circ.541
	Norm. Closed	S, H	No	Yes	No	Yes	see Note 2	
		S, H	No	Yes	No	Yes	Doors giving access to Ro-Ro Deck	SOLAS II-1/17.2
II. Cargo Ships								
A. At or below	Used	POS	Yes	Yes	Yes	No		SOLAS II-1/13-1.2
	Norm. Closed	S, H	No	Yes	No	Yes	see Notes 2 + 3 + 5	SOLAS II-1/13-1.3, II-1/24.4
	Perm. Closed	S, H	No	No	No	Yes	see Notes 1 + 4	SOLAS II-1/13-1.4, II-1/24.3, II-1/15-1, II-1/24.1
B. Above	Used	POS	Yes	Yes	Yes	No		SOLAS II-1/13-1.2
	Norm. Closed	S, H	No	Yes	No	Yes	See Notes 2 + 5	SOLAS II-1/13-1.3, II-1/15-1, II-1/24.1

Notes:

1. Doors in watertight bulkheads subdividing cargo spaces.
2. If hinged, this door is to be of quick acting or single action type.
3. "ICLL66+A.320" or "1988 Protocol to ICLL66", SOLAS, MARPOL, IGC and IBC- Codes require remotely operated watertight doors to be sliding doors.
4. The time of opening such doors in port and closing them before the ship leaves port are to be entered in the logbook.
5. The use of such doors is to be authorised by the officer of the watch.
6. Cables for control and power systems to power operated watertight doors and their status indication are to comply with the requirements of UR E15.
7. For ro-ro passenger ships constructed on or after 1 July 1997, "No" in last row, fifth column of I.B. is to be "Yes".

① Refer to SOLAS Reg.II-1/13-1.3, II-1/24.4.

Regulation 13.4

In cases where main and auxiliary propulsion machinery spaces, including boilers serving the needs for propulsion, are divided by watertight longitudinal bulkheads in order to comply with redundancy requirements (e.g., according to regulation 8-1.2), one watertight door in each watertight bulkhead may be permitted, as shown in the figure below.

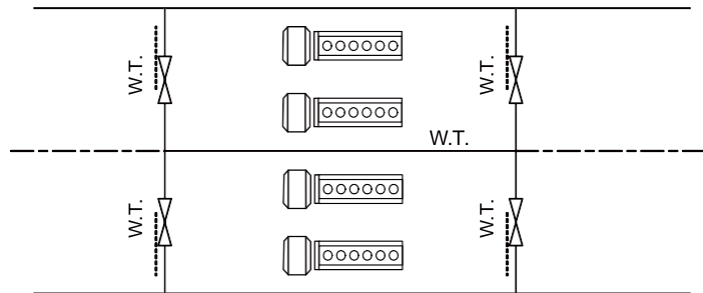

Regulation 13.7.6

The IEC standard referenced in the footnote (IEC publication 529, 1976) has been replaced by the newer standard IEC 60529:2003.

Regulation 13-1 Openings in watertight bulkheads and internal decks in cargo ships

General — Watertight doors and their controls, indication and alarms

For the requirements for provision of watertight doors and their controls, indication and alarms, see regulation 13 of the Guidelines.

Regulation 13-1.1

1 If the transverse watertight bulkheads in a region of the ship are carried to a higher deck than in the remainder of the ship, openings located in the bulkhead at the step may be considered as being located above the freeboard deck.

2 All openings in the shell plating below the upper deck throughout that region of the ship are to be treated as being below the freeboard deck, similar to the bulkhead deck for passenger ships (see relevant figure under regulation 13 above), and the provisions of regulation 15 are to be applied.

Regulation 13-1.4

Those hinged, rolling and sliding watertight doors and ramps which are fitted to subdivide large cargo spaces, and are not required to be remotely controlled, are not to be required to be fitted with a position indicator display at the bridge control position.

Regulation 14 Passenger ships carrying goods vehicles and accompanying personnel

General — Watertight doors and their controls, indication and alarms

An indicator is to be provided at the bridge. For the requirements for provision of watertight doors and their controls, indication and alarms, see regulation 13 of the Guidelines on passenger ships.

Regulation 15 Openings in the shell plating below the bulkhead deck of passenger ships and the freeboard deck of cargo ships

General — Steps in the bulkhead deck and freeboard deck

For the treatment of steps in the bulkhead deck of passenger ships, see regulation 13. For the treatment of steps in the freeboard deck of cargo ships, see regulation 13-1.

Regulations 15.8.3 and 15.10.2 —"readily accessible"

"Readily accessible" means

"during normal operating conditions:

- .1 located in a space normally entered without the use of tools;
- .2 clear of or protected from obstructions, moving equipment and hot surfaces that prevent operation or servicing; and
- .3 within arm's reach, or, within reach of a normally employed remote control device".

Regulation 15.9

For watertight gangway, cargo and fuelling ports which are immersed by an equilibrium or intermediate waterplane in damage stability calculation, see regulation 13 of the Guidelines for the requirements for provision of their controls, indication and alarms.

Regulation 15-1 External openings in cargo ships

General— Watertight doors and their controls, indication and alarms

Where the watertight doors specified in these provisions are immersed by an equilibrium or intermediate waterplane in damage stability calculation, see regulation 13 of the Guidelines on cargo ships for the requirements for provision of their controls, indication and alarms.

Regulation 15-1.1

With regard to air-pipe closing devices, they are to be considered weathertight closing devices (not watertight). This is consistent with their treatment in regulation 7-2.5.2.1. However, in the context of regulation 15-1, "external openings" are not intended to include air-pipe openings.

Regulation 16 Construction and initial tests of watertight doors, sidescuttles, etc.

General — Testing of watertight doors

For the testing, test head and leakage criteria, see regulation 13 of the Guidelines.

Regulation 16.2

1 Watertight doors are to be tested by water pressure to a head of water measured from the lower edge of the door opening to the bulkhead deck or the freeboard deck, or to the most unfavourable final or intermediate waterplane during flooding, whichever is greater.

2 Large doors, hatches or ramps on passenger and cargo ships, of a design and size that would make pressure testing impracticable, may be exempted from regulation 16.2, provided it is demonstrated by calculations that the doors, hatches or ramps maintain watertightness at design pressure with a proper margin of resistance. Where such doors utilize gasket seals, a prototype pressure test to confirm that the compression of the gasket material is capable of accommodating any deflection, revealed by the structural analysis, is to be carried out. After installation every such door, hatch or ramp is to be tested by means of a hose test or equivalent.

Note: See regulation 13 for additional information regarding the treatment of steps in the bulkhead deck of passenger ships. See regulation 13-1 for additional information regarding the treatment of steps in the freeboard deck of cargo ships.

Regulation 17 Internal watertight integrity of passenger ships above the bulkhead deck

General — Steps in the bulkhead deck

For the treatment of steps in the bulkhead deck of passenger ships, see regulation 13 of the Guidelines.

General — Watertight doors and their controls, indication and alarms

For these provisions regarding the requirements for provision of watertight doors and their controls, indication and alarms, see regulation 13 of the Guidelines.

Regulation 17.1

1 For the purpose of calculating the residual stability, it is necessary to establish flooding boundaries above the bulkhead deck.

2 For the purpose of establishing boundaries to satisfy the residual stability requirements, enclosed spaces included in the damage stability calculations may have weathertight subdivision if they do not become submerged during any stage of flooding, otherwise the subdivision is to be watertight.

3 Watertight doors installed in the spaces included in the damage stability calculations are to meet the requirements for power operated sliding watertight doors, except that the scantlings and sealing requirements could be reduced to the maximum head of water for their location.

4 When such doors are used above the bulkhead deck, there are to be at least two means of escape from each main vertical zone, at least one of which is to be independent of watertight doors and at least one of which is to give access to a stairway forming a vertical escape.

5 Doors fitted above the bulkhead deck which are required to meet both fire-protection and watertight requirements shall comply with the fire requirements in chapter II-2 and the watertight requirements in 3 above. The door must be capable of operation using both the remote fire door control circuit and the remote watertight door control circuit. If two doors are fitted, they must be capable of independent operation.

6 Watertight sliding doors with reduced pressure head complying with the requirements in 3 above are to be in line with regulation 7-2.5.2.1. These types of tested watertight sliding doors with reduced pressure head could be immersed during intermediate stages of flooding.

Regulation 17.3

These provisions regarding the open end of air pipes are to be applied only to damages of longitudinal and transverse extent as defined in regulation 8.3 but limited to the bulkhead deck and involving tanks having their open end terminating within the superstructure.

Regulation 17-1 Integrity of the hull and superstructure, damage prevention and control on ro-ro passenger ships

General — Watertight doors and their controls, indication and alarms

For these provisions regarding the requirements for provision of watertight doors and their controls, indication and alarms, see regulation 13 of the Guidelines.

Part B-4 STABILITY MANAGEMENT

Regulation 19 Damage control information

Regulation 19.1

1.1 All ships, regardless of damage stability requirements, are to be provided with damage control plan and damage control booklet in accordance with regulation 19. The damage control plan and damage control booklet are intended to provide ship's officers with clear information on the ship's watertight subdivision and equipment related to maintaining the boundaries and effectiveness of the subdivision so that, in the event of damage to the ship causing flooding, proper precautions can be taken to prevent progressive flooding through openings therein and effective action can be taken quickly to mitigate and, where possible, recover the ship's loss of stability.

1.2 The damage control plan and damage control booklet are to be clear and easy to understand. It is not to include information which is not directly relevant to damage control, and is to be provided in the working language of the ship. If the languages used in the preparation of the plan and booklet are not one of the official languages of the SOLAS Convention, a translation into one of the official languages is to be included.

2 The damage control plan is to show the following:

- (1) the watertight boundaries of the ship;
- (2) the locations and arrangements of cross-flooding systems, blow-out plugs and any mechanical means to correct list due to flooding, together with the locations of all valves and remote controls, if any;
- (3) the locations of all internal watertight closing appliances including, on ro-ro ships, internal ramps or doors acting as extension of the collision bulkhead and their controls and the locations of their local and remote controls, position indicators and alarms. The locations of those watertight closing appliances which are not allowed to be opened during the navigation and of those watertight closing appliances which are allowed to be opened during navigation, according to regulation 22.4, are to be clearly indicated;
- (4) the locations of all doors in the shell of the ship, including position indicators, leakage detection and surveillance devices;
- (5) the locations of all external watertight closing appliances in cargo ships, position indicators and alarms;
- (6) the locations of all weathertight closing appliances in local subdivision boundaries above the bulkhead deck and on the lowest exposed weather decks, together with locations of controls and position indicators, if applicable; and
- (7) the locations of all bilge and ballast pumps, their control positions and associated valves.

3 The damage control booklet is to include:

- (1) the information listed in 2 above is to be repeated in the damage control booklet;
- (2) the damage control booklet is to include general instructions for controlling the effects of damage, such as:
 - immediately closing all watertight and weathertight closing appliances;
 - establishing the locations and safety of persons on board, sounding tanks and compartments to ascertain the extent of damage and repeated soundings to determine rates of flooding; and
 - cautionary advice regarding the cause of any list and of liquid transfer operations to lessen list or trim, and the resulting effects of creating additional free surfaces and of initiating pumping operations to control the ingress of water.
- (3) The booklet is to contain additional details to the information^① shown on the damage control plan, such as the locations of flooding detection systems, sounding devices, tank vents and overflows which do not extend above the weather deck, pump capacities, piping diagrams, instructions for operating cross-flooding systems, means of accessing and escaping from watertight compartments below the bulkhead deck for use by damage control parties, and alerting ship management and other organizations to stand by and to co-ordinate assistance, if required.

① Equivalent plans may be provided in lieu of such information.

(4) If applicable to the ship, locations of non-watertight openings with non-automatic closing devices through which progressive flooding might occur are to be indicated as well as guidance on the possibility of non-structural bulkheads and doors or other obstructions retarding the flow of entering seawater to cause at least temporary conditions of unsymmetrical flooding.

(5) If the results of the subdivision and damage stability analyses are included, additional guidance is to be provided to ensure that the ship's officers referring to that information are aware that the results are included only to assist them in estimating the ship's relative survivability.

(6) The guidance is to identify criteria on which the analyses were based and clearly indicate that the initial conditions of the ship's loading extents and locations of damage, permeabilities, assumed for the analyses may have no correlation with the actual damaged condition of the ship.

4 Visual guidance, such as damage consequence diagrams, may be used to provide the master with a rapid means to evaluate the consequence of damage to the ship.

5 Placement on board the ship

(1) For passenger ships, the damage control plan is to be permanently exhibited or readily available on the navigation bridge, as well as in the ship's control station, safety centre or equivalent.

(2) For cargo ships, the damage control plan is to be permanently exhibited or readily available on the navigation bridge. Furthermore, the damage control plan is to be permanently exhibited or readily available in the cargo control room, all ship's offices or other suitable locations.

6 Use of on-board computers

Damage control plans and damage control booklets are to be in printed form. The use of on-board computers^①, with damage stability software developed for the specific ship, and familiar to properly trained ship's officers can provide a rapid means to supplement the information in the plan and booklet for effective damage control.

7 Shore-based emergency response systems

(1) A shore-based emergency response system may be used to supplement the damage control booklet referred to in 3 above.

(2) Contact information for gaining access to shore-based facilities together with a list of information required for making damage stability assessments are to be readily available.

Regulation 19.5

In case of ships to which damage stability requirements of part B-1 do not apply, damage control booklet need not to include the damage stability information.

Regulation 22 Prevention and control of water ingress, etc.

Regulation 22.4

^① Refer to the Guidelines for the on-board use and application of computers (MSC/Circ.891).

Certain watertight doors must remain open during navigation while it is essential to the safe and effective operation of the ship's machinery or to permit passengers normally unrestricted access throughout the passenger area. Such determination is to be made by the Administration only after careful consideration of the impact on ship operations and survivability. A watertight door permitted to remain thus open is to be clearly indicated in the ship's stability information.^①

Regulation 22-1 Flooding detection systems for passenger ships carrying 36 or more persons constructed on or after 1 July 2010

1 Flooding detection system means a system of sensors and alarms that detect and warn of water ingress into watertight spaces.

2 A flooding detection system is to be fitted in all watertight spaces below the bulkhead deck that have a volume that is more than the ship's moulded displacement per centimetre (cm) immersion at deepest subdivision draught or have a volume more than 30 m³, whichever is the greater.

3 Continuous flood level monitoring may be provided, but is not required.

4 Any watertight spaces that are separately equipped with a liquid level monitoring system are excluded from these requirements.

5 The number and location of flooding detection sensors is to ensure:

(1) vertical location — sensors are to be installed as low as practical in the watertight space;

(2) longitudinal location — in watertight spaces located forward of the mid-length, sensors are generally to be installed at the forward end of the space; and in watertight spaces located aft of the mid-length, sensors are generally to be installed at the aft end of the space. For watertight spaces located in the vicinity of the mid-length, consideration is to be given to the appropriate longitudinal location of the sensor. In addition, any watertight space of more than $L/5$ in length or with arrangements that would seriously restrict the longitudinal flow of water is to be provided with sensors at both the forward and aft ends.

6 Where a watertight space extends in height over more than one deck, there is to be at least one flooding detection sensor at each deck level. This provision is not applicable in cases where a continuous flood level monitoring system is installed.

7 Each flooding detection system is to give an audible and visual alarm at the navigation bridge and the safety centre, if located in a separate space from the navigation bridge. These alarms are to indicate which watertight space is flooded.

① Relevant guidelines are under development by IMO.

Appendix 1 Guidelines for the Preparation of Subdivision and Damage Stability Calculations

1 General

1.1 Purpose of the Guidelines

1.1.1 The Guidelines serves the purpose of simplifying the process of the damage stability analysis, as experience has shown that a systematic and complete presentation of the particulars results in considerable saving of time during the approval process.

1.1.2 A damage stability analysis serves the purpose to provide proof of the damage stability standard required for the respective ship type. At present, two different calculation methods, the deterministic concept and the probabilistic concept are applied.

1.2 Scope of analysis and documentation on board

1.2.1 The scope of subdivision and damage stability analysis is determined by the required damage stability standard and aims at providing the ship's master with clear intact stability requirements. In general, this is achieved by determining *KG*-respective *GM*-limit curves, containing the admissible stability values for the draught range to be covered.

1.2.2 Within the scope of the analysis thus defined, all potential or necessary damage conditions will be determined, taking into account the damage stability criteria, in order to obtain the required damage stability standard. Depending on the type and size of ship, this may involve a considerable amount of analyses.

1.2.3 Referring to SOLAS chapter II-1, Part B-4, regulation 19, the necessity to provide the crew with the relevant information regarding the subdivision of the ship is expressed, therefore plans are to be provided and permanently exhibited for the guidance of the officer in charge. These plans are to clearly show for each deck and hold the boundaries of the watertight compartments, the openings therein with means of closure and position of any controls thereof, and the arrangements for the correction of any list due to flooding. In addition, Damage Control Booklets containing the aforementioned information are to be available.

2 Documents for submission

2.1 Presentation of calculations

The calculation is to begin with the following details: principal dimensions, ship type, designation of intact conditions, designation of damage conditions and pertinent damaged compartments, *KG*-respective *GM*-limit curve.

2.2 General documents

For the checking of the input data, the following are to be submitted:

- .1 main dimensions;
- .2 lines plan, plotted or numerically;

- .3 hydrostatic data and cross curves of stability (including drawing of the buoyant hull);
- .4 definition of sub-compartments with moulded volumes, centres of gravity and permeability;
- .5 layout plan (watertight integrity plan) for the sub-compartments with all internal and external opening points including their connected sub-compartments, and particulars used in measuring the spaces, such as general arrangement plan and tank plan. The subdivision limits, longitudinal, transverse and vertical, are to be included;
- .6 light service condition;
- .7 load line draught;
- .8 coordinates of opening points with their level of tightness (e.g., weathertight, unprotected);
- .9 watertight door location with pressure calculation;
- .10 side contour and wind profile;
- .11 cross and down flooding devices and the calculations thereof according to resolution MSC.245(83) with information about diameter, valves, pipe lengths and coordinates of inlet/outlet;
- .12 pipes in damaged area when the destruction of these pipes results in progressive flooding; and
- .13 damage extensions and definition of damage cases.

2.3 Special documents

The following documentation of results are to be submitted.

2.3.1 Documentation

2.3.1.1 Initial data:

- .1 subdivision length L_s ;
- .2 initial draughts and the corresponding GM -values;
- .3 required subdivision index R ; and
- .4 attained subdivision index A with a summary table for all contributions for all damaged zones.

2.3.1.2 Results for each damage case which contributes to the index A :

- .1 draught, trim, heel, GM in damaged condition;
- .2 dimension of the damage with probabilistic values p , v and r ;
- .3 righting lever curve (including GZ_{\max} and range) with factor of survivability s ;
- .4 critical weathertight and unprotected openings with their angle of immersion; and
- .5 details of sub-compartments with amount of in-flooded water/lost buoyancy with their centres of gravity.

2.3.1.3 In addition to the requirements in paragraph 2.3.1.2, particulars of non-contributing damages ($s_i = 0$ and $p_i > 0.00$) are to be submitted for passenger ships and ro-ro ships fitted with long lower holds including full details of the calculated factors.

2.3.2 **Special consideration**

For intermediate conditions, as stages before cross-flooding or before progressive flooding, an appropriate scope of the documentation covering the aforementioned items is needed in addition.

Appendix 2 Cross-reference Tables of Regulations of SOLAS Chapter II-1

1 Amendments of SOLAS Chapter II-1

1.1 Annex 1 of resolution MSC.194(80) (entered into force on 1 January 2007):

(1) Part A: addition of the definition of bulk carrier (refer to regulation XII/1.1 for the definition of bulk carrier);

(2) editorial amendments to regulations 3-1 to 3-6 of Part A-1;

(3) new addition of regulations 3-7 and 3-8:

regulation 3-7—Construction drawings maintained onboard and ashore: This regulation stipulates a set of construction drawing and other plans showing any subsequent structural alterations are to be kept both onboard a ship and in the shore-based Company;

regulation 3-8—Towing and mooring equipment: This regulation stipulates the towing and mooring equipment necessary for normal operation of the ship;

(4) regulation 23-3 “Water level detectors on single hold cargo ships other than bulk carriers” Part B is added;

(5) regulation 31 “Machinery controls” of Part C stipulates ships constructed on or after 1 July 2004 shall comply with the requirements of paragraph 2.10 as added.

1.2 Annex 2 of resolution MSC.194(80) (entered into force on 1 January 2009)

The existing parts A, B and B-1 of SOLAS Chapter II-1 is replaced by the new text with the main content as follows:

(1) the existing regulation 21 is re-categorized as regulation 35-1 “Bilge pumping arrangements” of Part C, and the formulae of the criterion for service of passenger ships in the existing regulation II-1/6 is removed into the requirements for bilge bumping arrangements of passenger ship of regulation 35-1, with the name of “bilge pump numeral”. The relevant calculating data, such as “the length measured between perpendiculars taken at the extremities of the deepest subdivision load line”, is amended to “the length as defined in the International Convention on Load Lines in force”, and the existing “volume below the margin line” is amended to “the volume below the bulkhead deck”;

(2) the existing requirements for floodable length, criterion of service, factor of subdivision, as well as those for short international voyages are deleted;

(3) the existing requirements for deterministic damage stability for passenger ships are deleted, and new requirements for probabilistic damage stability for both passenger ships and cargo ships and stability requirements for minor damage to forward end in passenger ships are provided. The requirements for provision of double bottoms are amended, and for ships not complying with such requirements, bottom damage stability requirements are provided;

(4) higher requirements for conditions of inclining test of passenger ships and for lightweight survey are provided;

1.3 Annex 1 of resolution MSC.216(82) (entered into force on 1 July 2008)

The heading and content of regulation 3-2 of Part A-1 is amended. The existing heading “Corrosion prevention of seawater ballast tanks in oil tankers and bulk carriers” is replaced by “Protective coatings of dedicated seawater ballast tanks in all types of ships and double-side skin spaces of bulk carriers”.

1.4 Annex 2 of resolution MSC.216(82) (entered into force on 1 January 2009)

New regulations 8-1 and 22-1 are added on the basis of annex 2 of resolution MSC.194(80). Regulation 8-1 requires the systems and services are to remain operational on passenger ships for safe return to port after flooding caused by damage. Regulation 22-1 requires a flooding detection system for watertight spaces below the bulkhead deck is to be provided in passenger ships.

1.5 Annex 3 of resolution MSC.216(82) (entered into force on 1 July 2010):

(1) new paragraph 6 is added in the existing regulation 41 “Main source of electrical power and lighting systems” of Part D, which requires in passenger ships, supplementary lighting is to be provided in all cabins to clearly indicate the exit, and such lighting is to remain on for a minimum of 30 min;

(2) new Part F and regulation 55 “Alternative design and arrangements” are added.

2 Summary of the overall structure

SOLAS 2009		Existing SOLAS Chapter II-1	
Part A General	1 Application	Part A General	1 Application
	2 Definitions		2 Definitions
	3 Definitions relating to parts C, D and E		3 Definitions relating to parts C, D and E
Part A-1 Structure of ships	3-1 Structural, mechanical and electrical requirements for ships	Part A-1 Structure of ships	3-1 Structural, mechanical and electrical requirements for ships
	3-2 Protective coatings of dedicated seawater ballast tanks in all types of ships and double-side skin spaces of bulk carriers		3-2 Corrosion prevention of seawater ballast tanks in oil tankers and bulk carriers
	3-3 Safe access to tanker bows		3-3 Safe access to tanker bows
	3-4 Emergency towing arrangements on tankers		3-4 Emergency towing arrangements on tankers
	3-5 New installation of materials containing asbestos		3-5 New installation of materials containing asbestos
	3-6 Access to and within spaces in, and forward of, the cargo area of oil tankers and bulk carriers		3-6 Access to and within spaces in, and forward of, the cargo area of oil tankers and bulk carriers
	3-7 Construction drawings maintained on board and ashore		3-7 Construction drawings maintained on board and ashore
	3-8 Towing and mooring equipment		3-8 Towing and mooring equipment
Part B Subdivision and stability	4 General	Part B Subdivision and stability	4 Floodable length in passenger ships
			5 Permeability in passenger ships
Part B-1 Stability	5 Intact stability		6 Permissible length of compartments passenger ships
	5-1 Stability information to be supplied to the master		7 Special requirements concerning passenger ship subdivision
	6 Required subdivision index <i>R</i>		8 Stability of passenger ships in damaged condition
	7 Attained subdivision index <i>A</i>		8-1 Stability of ro-ro passenger ships in damaged condition
	7-1 Calculation of the factor <i>pi</i>		8-2 Special requirements for ro-ro passenger ships carrying 400 persons or more
	7-2 Calculation of the factor <i>si</i>		8-3 Special requirements for passenger ships, other than ro-ro passenger ships, carrying 400 persons or more
	7-3 Permeability		9 Ballasting of passenger ships
	8 Special requirements concerning passenger ship stability		10 Peak and machinery space bulkheads, shaft tunnels, etc., in passenger ships
8-1 System capabilities after a flooding casualty on passenger ships	11 Peak and machinery space bulkheads and stern tubes in cargo ships		
Part B-2 Subdivision, watertight and weathertight integrity	9 Double bottoms in passenger ships and cargo ships other than tankers	Part B Subdivision and stability (continued)	12 Double bottoms in passenger ships
	10 Construction of watertight bulkheads		12-1 Double bottoms in cargo ships other than tankers
	11 Initial testing of watertight bulkheads, etc.		13 Assigning, marking and recording of subdivision load lines for passenger ships
			14 Construction and initial testing of watertight bulkheads, etc., in passenger ships and cargo ships

SOLAS 2009		Existing SOLAS Chapter II-1	
	12 Peak and machinery space bulkheads, shaft tunnels, etc.		15 Openings in watertight bulkheads in passenger ships
	13 Openings in watertight bulkheads below the bulkhead deck in passenger ships		16 Passenger ships carrying goods vehicles and accompanying personnel
	13-1 Openings in watertight bulkheads and internal decks in cargo ships		17 Openings in the shell plating of passenger ships below the margin line
	14 Passenger ships carrying goods vehicles and accompanying personnel		17-1 Openings in the shell plating below the bulkhead deck of passenger ships and the freeboard deck of cargo ships
	15 Openings in the shell plating below the bulkhead deck of passenger ships and the freeboard deck of cargo ships		18 Construction and initial tests of watertight doors, sidescuttles, etc., in passenger ships and cargo ships
	15-1 External openings in cargo ships		19 Construction and initial tests of watertight decks, trunks, etc., in passenger ships and cargo ships
	16 Construction and initial tests of watertight doors, sidescuttles, etc.		20 Watertight integrity of passenger ships above the margin line
	16-1 Construction and initial tests of watertight decks, trunks, etc.		20-1 Closure of cargo loading doors
	17 Internal watertight integrity of passenger ships above the bulkhead deck		20-2 Watertight integrity from the ro-ro deck (bulkhead deck) to spaces below
	17-1 Integrity of the hull and superstructure, damage prevention and control on ro-ro passenger ships		20-3 Access to ro-ro decks
Part B-3 Subdivision load line assignment for passenger ships	18 Assigning, marking and recording of subdivision load lines for passenger ships		20-4 Closure of bulkheads on the ro-ro deck
			21 Bilge pumping arrangements
Part B-4 Stability management	19 Damage control information		22 Stability information for passenger ships and cargo ships
	20 Loading of passenger ships		23 Damage control plans in passenger ships
	21 Periodical operation and inspection of watertight doors, etc., in passenger ships		23-1 Damage control in dry cargo ships
	22 Prevention and control of water ingress, etc.		23-2 Integrity of the hull and superstructure, damage prevention and control
	22-1 Flooding detection systems for passenger ships		23-3 Water level detectors on single hold cargo ships other than bulk carriers
			24 Marking, periodical operation and inspection of watertight doors, etc., in passenger ships
Part B-1 Subdivision and damage stability of cargo ships			25 Entries in log of passenger ships
			25-1 Application
			25-2 Definitions
			25-3 Required subdivision index <i>R</i>
		25-4 Attained subdivision index <i>A</i>	

SOLAS 2009		Existing SOLAS Chapter II-1	
Part B-4 Stability management (continued)	23 Special requirements for ro-ro passenger ships	Part B-1 Subdivision and damage stability of cargo ships (continued)	25-5 Calculation of the factor p_i
	24 Prevention and control of water ingress, etc., in cargo ships		25-6 Calculation of the factor s_i
	25 Water level detectors on single hold cargo ships other than bulk carriers		25-7 Permeability
25-8 Stability information			
25-9 Openings in watertight bulkheads and internal decks in cargo ships			
	25-10 External openings in cargo ships		
Part C Machinery installations	Regulation 21 is re-categorized as regulation 35-1, inserted after the existing regulation 35	Part C Machinery installations	

3 Amendments of SOLAS 2009

No.	Regulation of SOLAS 2009	SOLAS 2009	Existing SOLAS Chapter II-1	Regulation of existing SOLAS Chapter II-1
Part A General				
Regulation 1 Application				
1	1.1	Applicable to ships the keels of which are laid or which are at a similar stage of construction on or after 1 January 2009	“1 July 1986”	SOLAS II-1/1.1.1
2	1.2	No amendment		SOLAS II-1/1.1.2
3	1.3.1 & 1.3.3	No amendment		SOLAS II-1/1.1.3.1 & 1.1.3.3
4	1.3.2	The expression “all ships” means ships constructed before, on or after 1 January 2009	Corresponding date: 1 July 1986	SOLAS II-1/1.1.3.2
5	1.3.4	Definition of “alterations and modifications of a major character” is added for cargo ships, and A/R ratio after modification is explained		MSC/Circ.650
6	2	The date is amended to “1 January 2009”	“1 July 1986”	SOLAS II-1/1.2
		For ships constructed before 1 January 2009, the requirements which are applicable under SOLAS II-2, as amended by resolutions adopted before 80th session of MSC are to be complied with on the basis of the existing MSC.1(XLV)	Resolution MSC.1(XLV)	
7	3	The date is amended to “the date on which any relevant amendments enter into force”	“1 July 1986”	SOLAS II-1/1.3
		The existing footnotes “Refer to MSC/Circ.650 on interpretation of alterations and modifications of a major character.” and “Refer to MSC/Circ.609 on interpretation of regulation II-1/1.3 of the 1974 SOLAS Convention.” are deleted		
8	4	No amendment		SOLAS II-1/1.4
9	5	No amendment		SOLAS II-1/1.5
Regulation 2 Definitions				
10	1	Subdivision length (L_s)		SOLAS II-1/25-2.2.1
11	2	Mid-length		SOLAS II-1/25-2.2.2
12	3	Aft terminal		SOLAS II-1/25-2.2.3

No.	Regulation of SOLAS 2009	SOLAS 2009	Existing SOLAS Chapter II-1	Regulation of existing SOLAS Chapter II-1
13	4	Forward terminal		SOLAS II-1/25-2.2.4
14	5	<i>Length (L)</i> is the length as defined in the International Convention on Load Lines in force	" <i>Length of the ships</i> is the length measured between perpendiculars taken at the extremities of the deepest subdivision load line"	SOLAS II-1/2.2; ICLL-1996
15	6	A new definition for "freeboard deck" is added		ICLL-1996
16	7	A new definition for "forward perpendicular" is added		ICLL-1996
17	8	<i>Breadth (B)</i> is the greatest moulded breadth of the ship at or below the deepest subdivision draught"	"...the extreme width from outside of frame to outside of frame at or below the deepest subdivision load line"	SOLAS II-1/2.3 & 25-2.3
18	9	<i>Draught (d)</i> is the vertical distance from the keel line at mid-length to the waterline in question	"...the vertical distance from the molded base line amidships to the subdivision load line in question"	SOLAS II-1/2.4 & 25-2.4
19	10	A new definition for "Deepest subdivision draught (d_s)" is added as "...the waterline which corresponds to the summer load line draught of the ship"	"Deepest subdivision load line"	SOLAS II-1/2.1.1 & 2.1.2 SOLAS II-1/25-2.1.2
20	11	A new definition for "Light service draught (d_l)" is added as "...the service draught corresponding to the lightest anticipated loading and associated tankage, including, however, such ballast as may be necessary for stability and/or immersion. Passenger ships should include the full complement of passengers and crew on board"		
21	12	<i>Partial subdivision draught (d_p)</i> is the light service draught plus 60% of the difference between the light service draught and the deepest subdivision draught	" <i>Partial load line</i> is the light ship draught plus 60% of the difference between the light ship draught and deepest subdivision load line"	SOLAS II-1/25-2.1.3
22	13	A new definition for "Trim" is added as "...the difference between the draught forward and the draught aft, where the draughts are measured at the forward and aft terminals respectively, disregarding any rake of keel		
23	14	The definition for "Permeability (μ)" in the existing regulation II-1/2.7 is replaced by that in the existing regulation II-1/25-2.5, and the text relating to margin line is deleted		SOLAS II-1/25-2.5
24	15	The definition for "Machinery spaces" is amended as "...spaces between the watertight boundaries of a space containing the main and auxiliary propulsion machinery, including boilers, generators and electric motors primarily intended for propulsion. In the case of unusual arrangements, the Administration may define the limits of the machinery spaces"	"...to be taken as extending from the moulded base line to the margin line and between the extreme main transverse watertight bulkheads, bounding the spaces containing the main and auxiliary propulsion machinery, boilers serving the needs of propulsion, and all permanent coal bunkers. In the case of unusual arrangements, ..."	SOLAS II-1/2.8
25	16	Definition for "Weathertight"		SOLAS II-1/2.11

No.	Regulation of SOLAS 2009	SOLAS 2009	Existing SOLAS Chapter II-1	Regulation of existing SOLAS Chapter II-1
26	17	A new definition for "Watertight" is added as "...having scantlings and arrangements capable of preventing the passage of water in any direction under the head of water likely to occur in intact and damaged conditions. In the damaged condition, the head of water is to be considered in the worst situation at equilibrium, including intermediate stages of flooding"		
27	18	A new definition for "Design pressure" is added		
28	19	<i>Bulkhead deck</i> in a passenger ship means the uppermost deck at any point in the subdivision length (<i>L_s</i>) to which the main bulkheads and the ship's shell are carried watertight and the lowermost deck from which passenger and crew evacuation will not be impeded by water in any stage of flooding for damage cases defined in regulation 8 and in part B-2 of this chapter. The bulkhead deck may be a stepped deck. In a cargo ship the freeboard deck may be taken as the bulkhead deck	" <i>Bulkhead deck</i> is the uppermost deck up to which the transverse watertight bulkheads are carried"	SOLAS II-1/2.5
29	20	Definition for "Deadweight"		SOLAS II-1/3.21
30	21	Definition for "Lightweight"		SOLAS II-1/3.22
31	22	Definition for "Oil tanker"		SOLAS II-1/2.12
32	23	Definition for "Ro-ro passenger ship", the existing footnote in the text is deleted		SOLAS II-1/2.13
33	24	Definition for "Bulk carrier"		SOLAS II-1/2.14
34	25	A new definition for "Keel line" is added		
35	26	A new definition for "Amidship" (at the middle of the length (<i>L</i>)) is added		
Regulation 3 Definitions relating to parts C, D and E				
36		The existing paragraphs 3.21 "Deadweight" and 3.22 "Lightweight" are removed as paragraphs 2.20 and 2.21 respectively, and others remain unchanged		SOLAS II-1/3
Regulation 3-2 Protective coatings of dedicated seawater ballast tanks in all types of ships and double-side skin spaces of bulk carriers (annex 1 of resolution MSC.216(82), entered into force on 1 July 2008)				
	Heading		Corrosion prevention of seawater ballast tanks in oil tankers and bulk carriers	Heading of SOLAS II-1/3-2
	1	Paragraphs 2 and 4 of this regulation shall apply to ships of not less than 500 gross tonnage for which the building contract is placed on or after 1 July 2008; or in the absence of a building contract, the keels of which are laid or which are at a similar stage of construction on or after 1 January 2009; or the delivery of which is on or after 1 July 2012		
	2	All dedicated seawater ballast tanks arranged in ships and double-side skin spaces arranged in bulk carriers of 150 m in length and upwards shall be coated during construction in accordance with resolution MSC.215(82)		

No.	Regulation of SOLAS 2009	SOLAS 2009	Existing SOLAS Chapter II-1	Regulation of existing SOLAS Chapter II-1
	3	All dedicated seawater ballast tanks arranged in oil tankers and bulk carriers constructed on or after 1 July 1998, for which paragraph 2 is not applicable, shall comply with the requirements of regulation II-1/3-2 adopted by resolution MSC.47(66)	Regulation II-1/3-2 adopted by resolution MSC.47(66)	SOLAS II-1/3-2
	4	Maintenance of the protective coating system shall be included in the overall ship's maintenance scheme. The effectiveness of the protective coating system shall be verified during the life of a ship by the Administration or an organization recognized by the Administration, based on the guidelines developed by IMO		
Part B Subdivision And Stability				
Regulation 4 General				
37	1	The application of damage stability is amended as "cargo ships of 80 m in length (L) and upwards and to all passenger ships regardless of length" In the footnote of "other instruments", the words in .1 "except OBO ships with type B freeboards are not excluded", and a new subparagraph .7 "Damage stability requirements of regulation 27 of the 1988 Load Lines Protocol, except ships intended for the carriage of deck cargo" are added	The application of damage stability is "cargo ships over 100 m in length (L_s) constructed on or after 1 February 1992, and cargo ships of 80 m in L_s and upwards but not exceeding 100 m in L_s constructed on or after 1 July 1998"	SOLAS II-1/25-1.1
38	2	No amendment		SOLAS II-1/25-1.3
39	3	The degree of subdivision is amended as "vary with the subdivision length (L_s) of the ship and with the service"	"The degree of subdivision shall vary with the length of the ship (meaning the maximum length of waterline at deepest subdivision draught) and with the service"	SOLAS II-1/6.1
40	4	No amendment		SOLAS II-1/8.2.2
Part B-1 Stability				
Regulation 5 Intact stability				
41	1	The last two sentences of the existing regulation 22.1 are removed into regulation 5-1.1		SOLAS II-1/22.1
42	2	The requirements are provided for satisfying the conditions for cargo sister ship: where a deviation from the lightship displacement exceeding 1% for ships of 160 m or more in length, and 2% for ships of 50 m or less in length, and as determined by linear interpolation for intermediate lengths, or a deviation from the lightship longitudinal centre of gravity exceeding 0.5% of L_s is found, the inclining test of such ship may be dispensed with upon completion	No detailed data for the conditions for re-inclining test of the sister ship is provided	SOLAS II-1/22.4

No.	Regulation of SOLAS 2009	SOLAS 2009	Existing SOLAS Chapter II-1	Regulation of existing SOLAS Chapter II-1
43	3	No amendment		SOLAS II-1/22.5
44	4	The requirements are provided for any alterations made to a ship so as to make lightweight or LCG exceed one of the values specified in paragraph 5, the ship is to be re-inclined	No detailed data for the conditions for re-inclining test due to alterations is provided	SOLAS II-1/22.2
45	5	The requirement for a deviation of the longitudinal centre of gravity is amended to “not exceeding 1% of L_s ”	“not exceeding 1% of L (where L — the maximum length of waterline at deepest subdivision draught)”	SOLAS II-1/22.3
46	6	No amendment		SOLAS II-1/8.7.3
Regulation 5-1 Stability information to be supplied to the master				
47	1	The requirements for supplying stability information to the master and Administration are removed from the existing regulation 22.1		SOLAS II-1/22.1
48	2.1	The subparagraph is amended as “curves or tables of minimum operational metacentric height (GM) versus draught which assures compliance with the relevant intact and damage stability requirements, alternatively corresponding curves or tables of the maximum allowable vertical centre of gravity (KG) versus draught, or with the equivalents of either of these curves;”	Only “curves” indicated	SOLAS II-1/25-8.1.1
49	2.2	No amendment		SOLAS II-1/25-8.1.2
50	2.3	The subparagraph is amended as “all other data and aids which might be necessary to maintain the required intact stability and stability after damage”	Only “stability after damage” required	SOLAS II-1/25-8.1.3
51	3	The requirements of “The stability information shall show the influence of various trims in cases where the operational trim range exceeds +/- 0.5% of L_s ” are provided		
52	4	The requirements for ships which have to fulfil the stability requirements of part B-1, the stability information is to include the limiting GM (or VCG) curves reflecting the actual trim (intact and damage stability included) are provided		
53	5	The requirements of “When curves or tables of minimum operational metacentric height (GM) versus draught are not appropriate, the master should ensure that the operating condition does not deviate from a studied loading condition, or verify by calculation that the stability criteria are satisfied for this loading condition” are provided		
Regulation 6 Required subdivision index R				
54	1	The words “the partial indices A_s , A_p and A_l are not less than $0.9R$ for passenger ships and $0.5R$ for cargo ships” are added		SOLAS II-1/25-3

No.	Regulation of SOLAS 2009	SOLAS 2009	Existing SOLAS Chapter II-1	Regulation of existing SOLAS Chapter II-1
55	2	The calculation of required subdivision index R is divided for passenger ships and cargo ships, and the formulae are different from the existing ones		SOLAS II-1/25-3
Regulation 7 Attained subdivision index A				
56	1	The formula for attained subdivision index A is different from the existing one, namely A_s , A_p and A_l weighted average as 4:4:2, and A_s , A_p and A_l are still calculated with the existing formula	Only A_s and A_p are calculated and weighted average as 5:5	SOLAS II-1/25-4.2
57	2	The requirements of “In the calculation of A , the level trim shall be used for the deepest subdivision draught and the partial subdivision draught. The actual service trim shall be used for the light service draught. If in any service condition, the trim variation in comparison with the calculated trim is greater than 0.5% of L_s , one or more additional calculations are to be submitted for...” are provided	“In calculating A , level trim shall be used”	SOLAS II-1/25-4.3
58	3	The requirements of “When determining the positive righting lever (GZ) of the residual stability curve, the displacement used should be that of the intact condition. That is, the constant displacement method of calculation should be used” are provided		MSC/Circ.649
59	4	A new text at the end of the subparagraph “In the case of unsymmetrical arrangements, the calculated A value should be the mean value obtained from calculations involving both sides. Alternatively, it should be taken as that corresponding to the side which evidently gives the least favourable result” is added		SOLAS II-1/25-4.5
60	5	The requirement for transverse extent not to be greater than one half of the ship breadth B ($0.5B$) is provided	A rectangular penetration not to extend the ship’s centerline	SOLAS II-1/25-4.6
61	6	The requirement for “In the flooding calculations carried out according to the regulations, ...and only one free surface need to be assumed” is provided		SOLAS II-1/25-4.7 & .9
62	7	No amendment		SOLAS II-1/25-4.8
Regulation 7-1 Calculation of the factor p_i				
63	1	Basic method for the calculation of factor p_i remains unchanged. This amendment is to the damage probability factor based on the latest statistic data on damage casualties, and the existing regulation II-1/25-5.3.2 “The factor p_i for a group of three or more adjacent compartments equals zero if the no dimensional length of such a group minus the nondimensional length of the aftermost and foremost compartments in the group is greater than J_{max} ” is deleted		SOLAS II-1/25-5

No.	Regulation of SOLAS 2009	SOLAS 2009	Existing SOLAS Chapter II-1	Regulation of existing SOLAS Chapter II-1
Regulation 7-2 Calculation of the factor s_i				
64	1—6	For passenger ships, the requirement for calculation of survival factors of heeling moment caused by movement of passengers, wind pressure or the launching of survival craft during the intermediate stages until the final equilibrium stage and after equilibrium stage, together with the survival factor calculated in final equilibrium stage, whichever is the least, is added. For cargo ships, the formula is the same as that of passenger ships, but only the survival factor in final equilibrium stage is to be calculated, and the formula is different from the existing one. In addition, requirements for the stability of cross-flooding arrangement during intermediate stages of flooding are provided. Horizontal escape route, vertical escape hatch are to be added in damage stability calculation in addition to air-pipes		SOLAS II-1/25-6
Regulation 7-3 Permeability				
65	1	The existing footnote “Whichever results in the more severe requirement” is removed as the note of the table, and the requirements for the permeability of spaces other than cargo spaces remain unchanged		SOLAS II-1/25-7
66	2	The permeabilities of dry cargo spaces, container spaces, ro-ro spaces and cargo liquids at draughts d_s , d_p and d_i , ranging from 0.7 to 0.95 respectively are added	Permeability of dry cargo spaces is taken as 0.70	
67	3	The requirement for “Other figures for permeability may be used if substantiated by calculations” is added		
Regulation 8 Special requirements concerning passenger ship stability				
68	1—3	Additional damage stability requirements for passenger ships intended to carry 400 or more persons and 36 or more persons are provided		
Regulation 8-1 System capabilities after a flooding casualty on passenger ships				
69	1—2	The requirements of “A passenger ship to which regulation II-2/21 applies shall be designed so that the systems remain operational when the ship is subject to flooding of any single watertight compartment” are provided, see for details in MSC.1/Circ.1214 “Performance standards for the systems and services to remain operational on passenger ships for safe return to port and orderly evacuation and abandonment after a casualty”		
Part B-2 Subdivision, Watertight And Weathertight Integrity				
Regulation 9 Double bottoms in passenger ships and cargo ships other than tankers				

No.	Regulation of SOLAS 2009	SOLAS 2009	Existing SOLAS Chapter II-1	Regulation of existing SOLAS Chapter II-1
70	1	The requirements for fitting of double bottoms within a certain range of length of passenger ships are deleted, and those for fitting of a double bottom extending from the collision bulkhead to the afterpeak bulkhead, as far as this is practicable are provided	The requirements for fitting of double bottoms in passenger ships vary to different length of the ships	SOLAS II-1/12.1, II-1/12-1.1
71	2	The requirement for height of double bottom: not to be less than 760 mm $\leq h = B/20 \leq 2,000$ mm	Requirements for height of double bottom: no specific data for cargo ships, and for passenger ships "the line of intersection of the outer edge of the margin plate with the bilge plating is not lower at any part than a horizontal plane passing through the point of intersection with the frame line amidships of a transverse diagonal line inclined at 25° to the base line and cutting it at a point one half the ship's moulded breadth from the middle line"	SOLAS II-1/12.2, II-1/12-1.2
72	3	The requirements of "In no case shall the vertical distance from the bottom of such a well to a plane coinciding with the keel line be less than 500 mm" are to be provided	460 mm for passenger ships, and no data for cargo ships	SOLAS II-1/12 & 12-1.3
73	4	The requirements of "A double bottom need not be fitted in way of watertight tanks, including dry tanks of moderate size, provided the safety of the ship is not impaired in the event of bottom or side damage" are provided	For passenger ships: "A double bottom need not be fitted in way of watertight compartments of moderate size used exclusively for the carriage of liquids, provided the safety of the ship, in the event of bottom or side damage, is not, in the opinion of the Administration, thereby impaired" For cargo ships: "A double bottom need not be fitted in way of watertight compartments used exclusively for the carriage of liquids, provided the safety of the ship in the event of bottom damage is not, in the opinion of the Administration, thereby impaired"	SOLAS II-1/12.4, II-1/12-1.4
74	5	Exemption requirements for the fitting of double bottom: for passenger ships which are employed in special trades for the carriage of large numbers of special trade passengers, such as the pilgrim trade, and engaged on regular service within the limits of a short international voyage, and the words "in any part of the ship which is subdivided by a factor not exceeding 0.50," is deleted	"...the ship which is subdivided by a factor not exceeding 0.50"	SOLAS II-1/12.5
75	6—8	The requirements for bottom damage stability where no double bottom is fitted or in the case of unusual bottom arrangements are added, and assumed extent of damage is provided		

No.	Regulation of SOLAS 2009	SOLAS 2009	Existing SOLAS Chapter II-1	Regulation of existing SOLAS Chapter II-1
76	9	The requirements of “In case of large lower holds in passenger ships, the Administration may require an increased double bottom height of not more than B/10 or 3 m, whichever is less, measured from the keel line. Alternatively, bottom damages may be calculated for these areas..., but assuming an increased vertical extent” are added		
Regulation 10 Construction of watertight bulkheads				
77	1	The requirements of “Each watertight subdivision bulkhead, whether transverse or longitudinal, shall be constructed having scantlings as specified in regulation 2.17. In all cases, watertight subdivision bulkheads shall be capable of supporting at least the pressure due to a head of water up to the bulkhead deck” are provided	“Each watertight subdivision bulkhead, whether transverse or longitudinal, shall be constructed in such a manner that it shall be capable of supporting, with a proper margin of resistance, the pressure due to the maximum head of water which it might have to sustain in the event of damage to the ship but at least the pressure due to a head of water up to the margin line. The construction of these bulkheads shall be to the satisfaction of the Administration”	SOLAS II-1/14.1
78	2	The existing regulation II-1/14.2.1 is removed as the subparagraph with editorial modification to the text, and the existing regulation II-1/14.2.2 “Where frames or beams pass through a watertight deck or bulkhead, such deck or bulkhead shall be made structurally watertight without the use of wood or cement.” is deleted		SOLAS II-1/14.2.1
Regulation 11 Initial testing of watertight bulkheads, etc.				
79	1	The range of testing compartments by filling water which are not compulsory is reduced to “...watertight spaces not intended to hold liquids and cargo holds intended to hold ballast...”	“...main compartments”	SOLAS II-1/14.3
80	2	The requirement for the pressure of the head is amended to “up to the bulkhead deck” as required by regulation 10.1	“...up to the margin line”	SOLAS II-1/14.4
81	3	For the requirements for water head, the words are amended as “...with water to a head corresponding to its design pressure. The water head is in no case to be less than the top of the air pipes or to a level of 2.4 m above the top of the tank, whichever is the greater.”, and the words “structural strength” are added after “for tightness” for the purpose of the test, the range is for the “tanks which are intended to hold liquids, and which form part of the watertight subdivision of the ship”	“...be tested for tightness with water to a head up to the deepest subdivision load line or to a head corresponding to two thirds of the depth from the top of keel to the margin line in way of the tanks, whichever is the greater; provided that in no case shall the test head be less than 0.9 m above the top of the tank” The only purpose of the test is “for tightness”	SOLAS II-1/14.5
82	4	No amendment		SOLAS II-1/14.6

No.	Regulation of SOLAS 2009	SOLAS 2009	Existing SOLAS Chapter II-1	Regulation of existing SOLAS Chapter II-1
Regulation 12 Peak and machinery space bulkheads, shaft tunnels, etc.				
83	1	The existing requirements for passenger ships and cargo ships are combined, and the words “this bulkhead shall be located at a distance from the forward perpendicular of not less than 5% of the length of the ship or 10 m, whichever is the less, and, except as may be permitted by the Administration, not more than 8% of the length of the ship” are replaced by “this bulkhead shall be located at a distance from the forward perpendicular of not less than 0.05L or 10 m, whichever is the less, and, except as may be permitted by the Administration, not more than 0.08L or 0.05L + 3 m, whichever is the greater.”, where “L” is the length as defined in Load Line Convention	The existing regulation 10.1 requires, for passenger ships: “a forepeak or collision bulkhead shall be located at a distance from the forward perpendicular of not less than 5% of the length of the ship and not more than 3 m plus 5% of the length of the ship”, and the existing regulation 11.2 requires, for cargo ships: “of not less than 5% of the length of the ship or 10 m, whichever is the less, and, except as may be permitted by the Administration, not more than 8% of the length of the ship”, where the length of the ship means “the maximum length of deepest subdivision waterline”	SOLAS II-1/10.1 & 11.2
84	2	The words “length of the ship” are amended as length (L)		SOLAS II-1/10.2 & 11.3
85	3	No amendment		The first sentence of SOLAS II-1/11.4
86	4	The existing requirements for passenger ships and cargo ships are combined, “margin line” relating to passenger ships is amended to “bulkhead deck”		The last sentence of SOLAS II-1/15.3.1 & 11.4
87	5.1	The requirements for the number and fitting of the pipe permitted to pierce the collision bulkhead below the bulkhead deck are from the existing regulation 15.3.2 for passenger ships, and those for the material of valves in the last two sentences are from the existing regulation 11.4		SOLAS II-1/11.4 & 15.3.2
88	5.2		Requirements for the fitting of pipes to pierce the collision bulkhead if the forepeak is divided to hold two different kinds of liquids	SOLAS II-1/15.3.3
89	6	The existing requirements for the extension of the collision bulkhead below the bulkhead deck where a long forward superstructure is fitted for both passenger ships and cargo ships are combined. For either passenger ships or cargo ships, such extension is to be so arranged as to preclude the possibility of the bow door causing damage to it in the case of damage to, or detachment of, a bow door		SOLAS II-1/10.3 & 11.5
90	7	The existing requirements for passenger ships and cargo ships where bow doors are fitted and a sloping loading ramp forms part of the extension of the collision bulkhead above the freeboard deck are combined, and the requirements for cargo ships still apply to cargo ships only		SOLAS II-1/10.5 & 11.6
91	8	No amendment		SOLAS II-1/11.7

No.	Regulation of SOLAS 2009	SOLAS 2009	Existing SOLAS Chapter II-1	Regulation of existing SOLAS Chapter II-1
92	9	The existing requirements for the bulkhead separating cargo and passenger spaces in passenger and cargo ships are combined, and the requirement of “an after peak bulkhead shall be fitted and made watertight up to the bulkhead deck” still applies to passenger ships only		SOLAS II-1/10.7 & 11.8
93	10	The existing requirements for stern tubes in passenger and cargo ships are combined, and the type of ships to which the regulations apply remains unchanged		SOLAS II-1/10.8 & 11.9
Regulation 13 Openings in watertight bulkheads below the bulkhead deck in passenger ships				
94	1	No amendment		SOLAS II-1/15.1
95	2.1—2.3	No amendment		SOLAS II-1/15.2.1—15.2.3
96	3	The words “...or from a permanent or reserve bunker” are deleted		SOLAS II-1/15.3.1.2
97	4	The words “main transverse bulkhead” are amended to “watertight bulkhead”, and words relating to “bunker” are deleted		SOLAS II-1/15.5
98	5.1—5.2	No amendment		SOLAS II-1/15.6.1&15.6.2
	5.3	The words “deepest subdivision load line” are amended to “deepest subdivision draught”		SOLAS II-1/15.6.3
	6	No amendment		SOLAS II-1/15.6.4
99	7.1	The existing subparagraph 7.1.2.3 for management requirements of power-operated sliding watertight door when the ship is at sea is deleted		SOLAS II-1/15.7.1
100	7.2—7.5	No amendment		SOLAS II-1/15.7.2—15.7.5
101	7.6	Reference in footnote is amended to “publication IEC 529 (1976)”, however the said standard is replaced by the new one “IEC 60529:2003”	The existing text of footnote: “IEC publication 60529 (1989), as amended by its amendment 1 (1999)”	SOLAS II-1/15.7.6
102	7.7 & 7.8	No amendment		SOLAS II-1/15.7 & 15.8
103	8.1—8.3	No amendment		SOLAS II-1/15.8.1—15.8.3
104	9.1	For outboard vertical edges of watertight doors fitted in watertight bulkheads dividing cargo between deck spaces, the words “measured at right angles to the centreline at the level of the deepest subdivision load line” are amended to “measured at right angles to the centreline at the level of the deepest subdivision draught”		SOLAS II-1/15.10.1
105	9.2	The first sentence in the existing regulation 15.10.2 “Such doors shall be closed before the voyage commences and shall be kept closed during navigation; the time of opening such doors in port and of closing them before the ship leaves port shall be entered in the log-book.” is removed to regulation 22.6, and only the technical requirements for construction of watertight doors fitted in watertight bulkheads dividing cargo between deck spaces are remained		SOLAS II-1/15.10.2

No.	Regulation of SOLAS 2009	SOLAS 2009	Existing SOLAS Chapter II-1	Regulation of existing SOLAS Chapter II-1
106	10	In the existing regulation 15.11, the sentence “Such plates (meaning for portable plates) shall always be in place before the ship leaves port, and shall not be removed during navigation except in case of urgent necessity at the discretion of the master” and the sentence “...the necessary precautions shall be taken in replacing them to ensure that the joints are watertight” are moved to regulation 22.5, and the sentence “The times of removal and replacement of any such portable plates shall be recorded in the log-book” is deleted, the management requirements of “The time of opening and closing these doors (meaning for portable plates), whether the ship is at sea or in port, shall be recorded in the log-book.” are removed to and amended in regulation 22.13		SOLAS II-1/15.11
107	11.1	The words in the existing regulation 15.12.1 “margin line” are amended to “bulkhead deck”, and “main transverse watertight bulkheads” amended to “watertight bulkheads”	“main transverse watertight bulkheads”	SOLAS II-1/15.12.1
108	11.2	The words “main transverse watertight bulkheads” are amended to “watertight bulkheads”	“main transverse watertight bulkheads”	SOLAS II-1/15.12.2
109	11.3	No amendment		SOLAS II-1/15.12.3
Regulation 13-1 Openings in watertight bulkheads and internal decks in cargo ships				
110	1 & 2	No amendment		SOLAS II-1/25-9.1 & 25-9.2
111	3	The requirements in the existing regulation 25-9.3 are removed to and amended in regulation 24.4	“The use of such doors and hatch covers shall be authorized by the officer of the watch.”	SOLAS II-1/25-9.3
112	4	The third sentence in the existing regulation 25-9.4 is removed as regulation 24.3	“Such doors or ramps shall be closed before the voyage commences and shall be kept closed during navigation; the time of opening such doors or ramps in port and of closing them before the ship leaves port shall be entered in the log-book.”	SOLAS II-1/25-9.4
113	5	No amendment		SOLAS II-1/25-9.5
Regulation 14 Passenger ships carrying goods vehicles and accompanying personnel				
114	1	The words in the existing regulation 16.1 “regardless of the date of construction” and “where the total number of persons on board, other than those specified in regulation I/2(e)(i) and (ii), exceeds 12” are deleted	“...regardless of the date of construction” “...where the total number of persons on board, other than those specified in regulation I/2(e)(i) and (ii), exceeds 12”	SOLAS II-1/16.1
115	2	The words “...where A = total deck area...” are amended to “...where “A _d ” = total deck area...”	“...where A = total deck area...”	SOLAS II-1/16.2
116	3	The requirements “The ship may not be certified for a higher number of passengers than assumed in paragraph 2, if a watertight door has been fitted in accordance with this regulation.” are added		

No.	Regulation of SOLAS 2009	SOLAS 2009	Existing SOLAS Chapter II-1	Regulation of existing SOLAS Chapter II-1
Regulation 15 Openings in the shell plating below the bulkhead deck of passenger ships and the freeboard deck of cargo ships				
117		Except for the words “deepest subdivision load line” amended to “deepest subdivision draught” and “margin line” amended to “the bulkhead deck of passenger ships and the freeboard deck of cargo ships” in related paragraphs of this regulation, the amendments are as follows:		
118	1 & 2	No amendment		SOLAS II-1/17.1 & 17.2
119	3.1 & 3.2	No amendment		SOLAS II-1/17.3.1 & 17.3.2
120	4	No amendment		SOLAS II-1/17.4
121	5.1&5.2	No amendment		SOLAS II-1/17.6.1 & 17.6.2
122	6	No amendment		SOLAS II-1/17.7
123	7	No amendment		SOLAS II-1/17.8
124	8.1 & 8.2	No amendment		SOLAS II-1/17.9.1 & 17.9.2
	8.3	The last sentence in the existing regulation 17.9.3 is amended as “In manned machinery spaces the valves may be controlled locally and shall be provided with indicators showing whether they are open or closed.”	“The valves may be controlled locally and shall be provided with indicators showing whether they are open or closed.”	SOLAS II-1/17.9.3
125	8.4	The new requirements of “Moving parts penetrating the shell plating below the deepest subdivision draught shall be fitted with a watertight sealing arrangement acceptable to the Administration. The inboard gland shall be located within a watertight space of such volume that, if flooded, the bulkhead deck will not be submerged. The Administration may require that if such compartment is flooded, essential or emergency power and lighting, internal communication, signals or other emergency devices must remain available in other parts of the ship.” are added		SOLAS II-1/10.8,11.9,17.2
	8.5	No amendment		SOLAS II-1/17.9.4
126	9	The existing requirements for strength and management are deleted and those for watertightness are remained, and the words “coaling ports” are amended to “fuelling ports”: “Gangway, cargo and fuelling ports fitted below the bulkhead deck of passenger ships and the freeboard deck of cargo ships shall be watertight and in no case be so fitted as to have their lowest point below the deepest subdivision draught.”	“Gangway, cargo and coaling ports fitted below the margin line shall be of sufficient strength. They shall be effectively closed and secured watertight before the ship leaves port, and shall be kept closed during navigation.”	SOLAS II-1/17.10.1 & 17.10.2
	10.1	No amendment		SOLAS II-1/17.11.1
127	10.2	The words “margin line” in the existing regulation 17.11.2 are amended to “the bulkhead deck of passenger ships and the freeboard deck of cargo ships”, and the last sentence “When the chute is not in-use both the cover and the valve shall be kept closed and secured.” is removed as regulation 22.17		SOLAS II-1/17.11.2

No.	Regulation of SOLAS 2009	SOLAS 2009	Existing SOLAS Chapter II-1	Regulation of existing SOLAS Chapter II-1
Regulation 15-1 External openings in cargo ships				
128	1	No amendment		SOLAS II-1/25-10.1
129	2	The requirement for the strength of openings is deleted		SOLAS II-1/25-10.2
130	3	The requirement "Openings in the shell plating below the deck limiting the vertical extent of damage shall be kept permanently closed while at sea" is removed as regulation 24.1		SOLAS II-1/25-10.3
131	4	No amendment		SOLAS II-1/25-10.5
Regulation 16 Construction and initial tests of watertight doors, sidescuttles, etc.				
132	1	The words "In passenger ships" are amended to "In all ships"	"passenger ships"	SOLAS II-1/18.1
133	1.1	The words "coaling ports" are deleted		SOLAS II-1/18.1.1
134	1.2	The requirements of "such valves, doors and mechanisms shall be suitably marked to ensure that they may be properly used to provide maximum safety" are added		
135	1.3	No amendment		SOLAS II-1/18.1.2
136	2	1 The existing text is amended to "...tested by water pressure to a head of water they might sustain in a final or intermediate stage of flooding" 2 Where testing of individual doors is not carried out because of possible damage to insulation or outfitting items, a prototype pressure test may be carried out instead before the door is fitted, and the requirements for the test and installation are provided.	"...tested by water pressure to a head up to the bulkhead deck or freeboard deck respectively"	SOLAS II-1/18.2
Regulation 16-1 Construction and initial tests of watertight decks, trunks, etc.				
137	1	No amendment		SOLAS II-1/19.1
138	2	Apply to all ships, the words "in ro-ro passenger ships" are deleted, and the footnote "The Maritime Safety Committee, at its sixty-eighth session, agreed that paragraphs 2, 3 and 4 should commence with the words 'In ro-ro passenger ships'." is deleted accordingly		SOLAS II-1/19.2
139	3	Apply to all ships, and the words "In ro-ro passenger ships" are deleted		SOLAS II-1/19.3
140	4	No amendment		SOLAS II-1/19.5
Regulation 17 Internal watertight integrity of passenger ships above the bulkhead deck				
141	1	A new sentence "Where openings, pipes, scuppers, electric cables etc. are carried through the partial watertight bulkheads or decks within the immersed part of the bulkhead deck, arrangements shall be made to ensure the watertight integrity of the structure above the bulkhead deck." is added		SOLAS II-1/20.1

No.	Regulation of SOLAS 2009	SOLAS 2009	Existing SOLAS Chapter II-1	Regulation of existing SOLAS Chapter II-1
142	2	The first sentence "The bulkhead deck or a deck above it shall be watertight." is deleted		SOLAS II-1/20.2
143	3	The words "In passenger ships constructed on or after 1 July 1997," is deleted		SOLAS II-1/20.3
144	4	The words "coaling ports" are amended to "fuelling ports", "margin line" amended to "bulkhead deck", and "deepest subdivision load line" amended to "deepest subdivision draught"		SOLAS II-1/20.4
145	5	No amendment		SOLAS II-1/20.5
Regulation 17-1 Integrity of the hull and superstructure, damage prevention and control on ro-ro passenger ships				
146	1.1—1.3	No amendment		SOLAS II-1/20-2.1.1—20-2.1.3
147	2	The last sentence "The indicator systems, approved by the Administration, which were installed on ships constructed before 1 July 1997 need not be changed." is deleted		SOLAS II-1/23-2.1
148	3	No amendment		SOLAS II-1/23-2.2
Part B-3 Subdivision Load Line Assignment For Passenger Ships				
Regulation 18 Assigning, marking and recording of subdivision load lines for passenger ships				
149	1	The words are amended as "A ship intended for alternating modes of operation..." A new sentence "Each service configuration so approved shall comply with part B-1 of this chapter independently of the results obtained for other modes of operation." is added	"A ship having spaces which are specially adapted for the accommodation of passengers and the carriage of cargo alternatively"	SOLAS II-1/13.1
150	2	Notations for the modes of operation are amended as "P1 for the principal passenger service configuration, and P2, P3, etc., for the alternative configurations" A new sentence "The principal passenger configuration shall be taken as the mode of operation in which the required subdivision index <i>R</i> will have the highest value." is added	"C.1, C.2, C.3..."	SOLAS II-1/13.2
151	3—7	No amendment		SOLAS II-1/13.3—13.7
Part B-4 Stability Management				
Regulation 19 Damage control information (Note: the existing regulations 23 for passenger ships and 23-1 for cargo ships are combined, with no footnote referring to MSC/Circ.919 for the heading of regulation 23)				
152	1	The footnote is amended as "Refer to the Guidelines for damage control plans (MSC/Circ.919)."	The existing footnote: "Refer to MSC/Circ.434, Guidelines for the preparation of information on the effect of flooding to be provided to masters of dry cargo ships."	SOLAS II-1/23-1.1

No.	Regulation of SOLAS 2009	SOLAS 2009	Existing SOLAS Chapter II-1	Regulation of existing SOLAS Chapter II-1
153	2			Last sentence of SOLAS II-1/15.9.3
154	3	No amendment		SOLAS II-1/23-1.3.1
155	4	The words "...the ship and its crew" is amended to "...the ship, passengers and crew"		SOLAS II-1/23-1.3.2
156	5	The requirements of "In case of ships to which damage stability requirements of part B-1 apply, damage stability information shall provide the master a simple and easily understandable way..." are provided		
Regulation 20 Loading of passenger ships				
157	1	No amendment		SOLAS II-1/8.7.4
158	2 & 3	No amendment		SOLAS II-1/9.1 & 9.2
Regulation 21 Periodical operation and inspection of watertight doors, etc. in passenger ships				
159	1	No amendment		SOLAS II-1/24.2.1
160	2	The words "in main transverse bulkheads" are amended to "in watertight bulkheads"		SOLAS II-1/24.2.2
161	3	No amendment		SOLAS II-1/24.3.1
162	4	No amendment		SOLAS II-1/25.3
Regulation 22 Prevention and control of water ingress, etc.				
163	1	"Watertight doors of a width of more than 1.2 m in machinery spaces as permitted by regulation 13.10 may only be opened in the circumstances detailed in that regulation."	"Watertight doors of width of more than 1.2 m permitted by paragraph 11 may only be opened in the circumstances detailed in that paragraph."	SOLAS II-1/15.9.1
164	2	"Watertight doors located below the bulkhead deck having a maximum clear opening width of more than 1.2 m shall be kept closed when the ship is at sea, except for limited periods when absolutely necessary as determined by the Administration."	"the door shall be kept closed when the ship is at sea, except for limited periods when absolutely necessary as determined by the Administration"	SOLAS II-1/15.7.1.2.3
165	3 & 4	No amendment		SOLAS II-1/15.9.2&15.9.3
166	5	See regulation 13.10		SOLAS II-1/15.11
167	6	See regulation 13.9.2		SOLAS II-1/15.10.2
168	7	The words "coaling ports" amended to "fuelling ports", and "margin line" amended to "bulkhead deck"		SOLAS II-1/17.10.1
169	8	The words "margin line" are amended to "bulkhead deck", "watertight ramps" amended to "ramps", and the text at the end of the sub-paragraph "Provided that where a door cannot be opened or closed while the ship is at the berth such a door may be opened or left open while the ship approaches or draws away from the berth, but only so far as may be necessary to enable the door to be immediately operated. In any case, the inner bow door must be kept closed." is removed as new paragraph 9		SOLAS II-1/20-1.2
	9	No amendment		The subparagraph at the end of regulation 20-1.2

No.	Regulation of SOLAS 2009	SOLAS 2009	Existing SOLAS Chapter II-1	Regulation of existing SOLAS Chapter II-1
170	10	No amendment		SOLAS II-1/20-1.3
	11	No amendment		SOLAS II-1/20-1.4
171	12	The words “paragraph 14” are to be editorially amended to “paragraph 10”, and “paragraph 13” to be editorially amended to “paragraphs 8 and 9”		SOLAS II-1/20-1.5
172	13	The words “coaling ports” are amended to “fuelling ports”		SOLAS II-1/25.2
173	14	No amendment		SOLAS II-1/17.3.3.1
	14.1	No amendment		SOLAS II-1/17.3.3.2
	14.2	The words “deepest subdivision load line” are amended to “deepest subdivision draught”		SOLAS II-1/17.3.3.3
174	15	No amendment		SOLAS II-1/17.5
175	16	No amendment		SOLAS II-1/17.6.3
176	17	No amendment		Last sentence of SOLAS II-1/17.11.2
Regulation 22-1 Flooding detection systems for passenger ships carrying 36 or more persons constructed on or after 1 July 2010				
		Passenger ships carrying 36 or more persons constructed on or after 1 July 2010 are required to be provided with a flooding detection system for watertight spaces below the bulkhead deck (specific technical requirements are under development by IMO)		
Regulation 23 Special requirements for ro-ro passenger ships				
177	1 & 2	No amendment		SOLAS II-1/23-2.3 & 23-2.4
178	3	The requirements for accesses required to be closed before the ship leaves the berth are amended as “All accesses from the ro-ro deck and vehicle ramps that lead to spaces below the bulkhead deck...”	“all accesses from the ro-ro deck that lead to spaces below the bulkhead deck...”	SOLAS II-1/20-2.2.2
179	4 & 5	No amendment		SOLAS II-1/20-2.1.5 & 20-2.1.6
180	6	No amendment		SOLAS II-1/20-2.2.3
181	7 & 8	No amendment		SOLAS II-1/20-4.1 & 20-4.2
182	9	No amendment		SOLAS II-1/20-3
Regulation 24 Prevention and control of water ingress, etc., in cargo ships				
183	1	The requirements of “Openings in the shell plating below the deck limiting the vertical extent of damage shall be kept permanently closed while at sea.” are provided		First sentence of SOLAS II-1/25-10.3
184	2	The words “paragraph 3” in regulation 24.2 are to be editorially amended to “paragraph 1”		SOLAS II-1/25-10.4

No.	Regulation of SOLAS 2009	SOLAS 2009	Existing SOLAS Chapter II-1	Regulation of existing SOLAS Chapter II-1
185	3	The management requirements of "...the time of opening such doors or ramps in port and of closing them before the ship leaves port shall be entered in the log-book" are removed from the existing regulation II-1/25-9.4		SOLAS II-1/25-9.4
186	4	The management requirements in the existing regulation II-1/25-9.3 are removed and amended as "The use of access doors and hatch covers intended to ensure the watertight integrity of internal openings shall be authorized by the officer of the watch."		Last sentence of SOLAS II-1/25-9.3
Regulation 25 Water level detectors on single hold cargo ships other than bulk carriers				
187	1	The requirements of "Single hold cargo ships other than bulk carriers constructed before 1 January 2007 shall comply with the requirements of this regulation not later than 31 December 2009." are provided	"Single hold cargo ships other than bulk carriers constructed before 1 January 2007 shall comply with the requirements of this regulation not later than the date of the first intermediate or renewal survey of the ship to be carried out after 1 January 2007, whichever comes first."	SOLAS II-1/23-3.1
188	2	The length (<i>L</i>) applied to ships is the length as defined in the Load Line Convention	Literally, the length of the ship (<i>L</i>) is the length defined in the existing regulation 2 (the maximum length of the deepest subdivision waterline), but in fact (a length (<i>L</i>) of less than 80 m, or 100 m if constructed before 1 July 1998), it is to be the subdivision length of the ship (<i>L_s</i>) as defined in the existing regulation 25-2	SOLAS II-1/23-3.3
189	3			SOLAS II-1/23-3.4
190	4			SOLAS II-1/23-3.5
Part C Machinery Installations				
Regulation 35-1 Bilge pumping arrangements				
191	1	The note for the existing heading is amended as regulation 35-1.1 "This regulation applies to ships constructed on or after 1 January 2009."		SOLAS II-1/21
192	2	No amendment		SOLAS II-1/21.1
193	3.1	No amendment		SOLAS II-1/21.2.1

No.	Regulation of SOLAS 2009	SOLAS 2009	Existing SOLAS Chapter II-1	Regulation of existing SOLAS Chapter II-1
194	3.2	The formulae for “the criterion of service numeral” in the existing regulation II-1/6 is removed to this paragraph, “the criterion of service numeral” is amended as “bilge pump numeral”, the three whole volumes (machinery space, passenger space, the ship) below the margin line are replaced by the relevant whole volume below the bulkhead deck, and the length of the ship (maximum length of deepest subdivision waterline) is replaced by the length as defined in the Load Line Convention		SOLAS II-1/2.9 SOLAS II-1/6.3.1 & 6.3.2 SOLAS II-1/21.2.2
195	3.3—3.8	No amendment		SOLAS II-1/21.2.3—21.2.8
	3.9	The “length of the ship” in the formula for calculation of the diameter d of the bilge main is replaced by the length as defined in the Load Line Convention	The maximum length of the deepest subdivision waterline	SOLAS II-1/21.2.9
196	3.10—3.12	No amendment		SOLAS II-1/21.2.10—21.2.12
196		No amendment		SOLAS II-1/21.3
Part D Electrical Installations				
Regulation 41 Main source of electrical power and lighting systems				
	1—5	No amendment		
	6	The requirements of “In passenger ships, supplementary lighting shall be provided in all cabins to clearly indicate the exit so that occupants will be able to find their way to the door. Such lighting, which may be connected to an emergency source of power or have a self-contained source of electrical power in each cabin, shall automatically illuminate when power to the normal cabin lighting is lost and remain on for a minimum of 30 min.” are provided (enter into force on 1 July 2010)		
Part F Alternative Design And Arrangements (enter into force on 1 July 2010)				
Regulation 55 Alternative design and arrangements				
	1	Purpose: “The purpose of this regulation is to provide a methodology for alternative design and arrangements for machinery and electrical installations.”		SOLAS II-1/21
	2	General: “Machinery and electrical installation design and arrangements may deviate from the requirements set out in parts C, D and E, provided that the alternative design and arrangements meet the intent of the requirements concerned and provide an equivalent level of safety to this chapter.”, and “an engineering analysis, evaluation and approval of the design and arrangements shall be carried out in accordance with this regulation.”		SOLAS II-1/21

No.	Regulation of SOLAS 2009	SOLAS 2009	Existing SOLAS Chapter II-1	Regulation of existing SOLAS Chapter II-1
	3	Engineering analysis: The engineering analysis shall be prepared, based on the Guidelines on alternative design and arrangements (MSC.1/Circ.1212), mainly including as a minimum the assumptions used in the design and proposed operational restrictions or conditions, technical justification demonstrating that the alternative design and arrangements meet a level of safety performance criteria specified in parts C, D and E, and risk assessment based on identification of the potential faults and hazards associated with the proposal		SOLAS II-1/21
	4	Evaluation: The engineering analysis required in paragraph 3 shall be evaluated and approved by the Administration, taking into account MSC.1/Circ.1212, and a copy of the documentation, as approved by the Administration shall be carried on board the ship		SOLAS II-1/21
	5	The Administration shall communicate to IMO pertinent information concerning alternative design and arrangements approved by them for circulation to all Contracting Governments		SOLAS II-1/21
	6	If the assumptions and operational restrictions that were stipulated in the alternative design and arrangements are changed, re-evaluation of the engineering analysis shall be carried out under the changed condition and shall be approved by the Administration		SOLAS II-1/21

4 Development of the existing SOLAS Chapter II-1

Reg.	Regulations of existing SOLAS Chapter II-1	Regulations of SOLAS 2009	Remark
Part A General			
1	Application	Regulation 1	
2	Definitions	Regulation 2	
3	Definitions relating to Parts C, D and E	Regulation 3	
Part A-1 Structure of ships			
3-1	Structural, mechanical and electrical requirements for ships	Regulation 3-1	
3-2	Corrosion prevention of seawater ballast tanks in oil tankers and bulk carriers	Regulation 3-2	
3-3	Safe access to tanker bows	Regulation 3-3	
3-4	Emergency towing arrangements on tankers	Regulation 3-4	
3-5	New installation of materials containing asbestos	Regulation 3-5	
3-6	Access to and within spaces in, and forward of, the cargo area of oil tankers and bulk carriers	Regulation 3-6	
3-7	Construction drawings maintained on board and ashore	Regulation 3-7	
3-8	Towing and mooring equipment	Regulation 3-8	
Part B Subdivision and stability			
4	Floodable length in passenger ships	—	Deleted
5	Permeability in passenger ships	Regulation 7-3	
6	Permissible length of compartments passenger ships	—	Deleted
7	Special requirements concerning passenger ship subdivision	Regulation 8	
8	Stability of passenger ships in damaged condition	—	Deleted
8-1	Stability of ro-ro passenger ships in damaged condition	—	Deleted
8-2	Special requirements for ro-ro passenger ships carrying 400 persons or more	—	Deleted
8-3	Special requirements for passenger ships, other than ro-ro passenger ships, carrying 400 persons or more	—	Deleted
9	Ballasting of passenger ships	Regulation 20	
10	Peak and machinery space bulkheads, shaft tunnels, etc., in passenger ships	Regulation 12	
11	Peak and machinery space bulkheads and stern tubes in cargo ships	Regulation 12	
12	Double bottoms in passenger ships	Regulation 9	
12-1	Double bottoms in cargo ships other than tankers	Regulation 9	
13	Assigning, marking and recording of subdivision load lines for passenger ships	Regulation 18	
14	Construction and initial testing of watertight bulkheads, etc., in passenger ships and cargo ships	Regulations 10 and 11	
15	Openings in watertight bulkheads in passenger ships	Regulation 13-1	

Reg.	Regulations of existing SOLAS Chapter II-1	Regulations of SOLAS 2009	Remark
16	Passenger ships carrying goods vehicles and accompanying personnel	Regulation 14	
17	Openings in the shell plating of passenger ships below the margin line	Regulation 15	
17-1	Openings in the shell plating below the bulkhead deck of passenger ships and the freeboard deck of cargo ships	—	Deleted
18	Construction and initial tests of watertight doors, sidescuttles, etc., in passenger ships and cargo ships	Regulation 16	
19	Construction and initial tests of watertight decks, trunks, etc., in passenger ships and cargo ships	Regulation 16-1	
20	Watertight integrity of passenger ships above the margin line	Regulation 17	
20-1	Closure of cargo loading doors	Regulation 22	
20-2	Watertight integrity from the ro-ro deck (bulkhead deck) to spaces below	Regulation 23	
20-3	Access to ro-ro decks	Regulation 23	
20-4	Closure of bulkheads on the ro-ro deck	Regulation 23	
21	Bilge pumping arrangements	Regulation 35-1	
22	Stability information for passenger ships and cargo ships	Regulations 5 and 5-1	
23	Damage control plans in passenger ships	Regulation 19	
23-1	Damage control in dry cargo ships	Regulation 19	
23-2	Integrity of the hull and superstructure, damage prevention and control	Regulations 17-1 and 23	
23-3	Water level detectors on single hold cargo ships other than bulk carriers	Regulation 25	
24	Marking, periodical operation and inspection of watertight doors, etc., in passenger ships	Regulation 21	
25	Entries in log of passenger ships	Regulation 21	
Part B-1 Subdivision and damage stability of cargo ships			
25-1	Application	Regulation 4	
25-2	Definitions	Regulation 2	
25-3	Required subdivision index R	Regulation 6	
25-4	Attained subdivision index A	Regulation 7	
25-5	Calculation of the factor p_i	Regulation 7-1	
25-6	Calculation of the factor s_i	Regulation 7-2	
25-7	Permeability	Regulation 7-3	
25-8	Stability information	Regulation 5-1	
25-9	Openings in watertight bulkheads and internal decks in cargo ships	Regulations 13-1 and 24	
25-10	External openings in cargo ships	Regulations 15-1 and 24	

Appendix 3 List of Relevant Instruments

IMO Circulars

Circ No.	Title	Regulations of existing SOLAS Chapter II-1	Regulations of SOLAS 2009
MSC/Circ.541	Guidance notes on the integrity of flooding boundaries above the bulkhead deck of passenger ships for proper application of regulations II-1/8 and 20, paragraph 1, of the 1974 SOLAS convention, as amended	Footnote ^① of regulation II-1/20.1	II-1/17.1
		Footnote ^① of regulation II-1/20-1.1	
MSC/Circ.651	Interpretations of regulations of part B-1 of SOLAS Chapter II-1 (SOLAS reg. II-1/25-7, reg. II-1/25-8, reg. II-1/25-9)	Footnote ^② of regulation II-1/25-9.4	II-1/13-1.4
MSC/Circ.734	Interpretations of phrases on human performance criteria in SOLAS Chapter II-1	II-1/17.9.3 —“readily accessible”	II-1/15.8.3
		II-1/17.11.2 —“easily accessible”	II-1/15.10.2
MSC/Circ.855	Interpretation of the position of the forward perpendicular for the purpose of SOLAS regulation II-1/10	II-1/10	II-1/2.7
			II-1/12
MSC/Circ.998	IACS Unified Interpretation regarding timber deck cargo in the context of damage stability requirements	Part B-1	Part B-1
MSC.1/Circ.1245	Guidelines for damage control plans and information to the master		Footnote of Reg.19.1
MSC.1/Circ.1158	Unified Interpretation of SOLAS Chapter II-1	II-1/22	II-1/5
MSC.1/Circ.1284	Unified Interpretations of SOLAS regulations II-1/1.3 and II-1/3-6	II-1/1.3.1	II-1/1.3
MSC.1/Circ.1291	Guidelines for flooding detection systems on passenger ships		II-1/22-1

IACS Unified Interpretations (UI)

IACS UI No.	Title	Regulations of existing SOLAS Chapter II-1	Regulations of SOLAS 2009
SC93	Enclosure of stern tubes on cargo ships	II-1/11.9	II-1/12.10
SC155	Lightweight check in lieu of inclining test	II-1/22	II-1/5
SC156	Doors in watertight bulkheads of cargo ships and passenger ships	II-1/15 II-1/25-9 II-1/25-10	II-1/22 II-1/13 II-1/13-1 II-1/15-1
SC161	Timber deck cargo in the context of damage stability requirements	Existing probabilistic damage stability regulations of SOLAS	New probabilistic damage stability regulations for both passenger ships and cargo ships
SC224	Measurement of distances	II-1/25-2.2.1	II-1/2.1
SC225	The occupied volume by flooded water of a flooded space in the SOLAS Chapter II-1 (Regulation 2(14))	II-1/25-2.5	II-1/2.14
SC226	IACS Unified Interpretations (UI) for the application of SOLAS regulations to conversions of Single Hull Tanker to Double Hull Tanker or Bulk Carrier/ Ore Carrier	II-1/1.3.1	II-1/1.3